

## Technical Specification

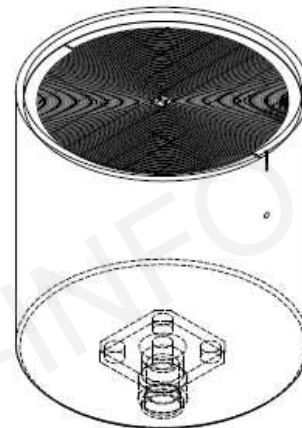

Polarization	RHCP or LHCP
Frequency Range(GHz)	4 - 8
Gain(dBic)	2.14 @4GHz
	3.86 @8GHz
Axial Ratio(dB)	3.0 Max.
VSWR	1.5 Typ.
	2.0 Max.
3dB Beamwidth(deg)	E: 120-65
	H: 105-60
Connector	SMA-Female
Size(mm)	Φ37.5 x 49.4 Approx.
Net Weight(Kg)	0.06 Around

## Outline Drawing (Size: mm)

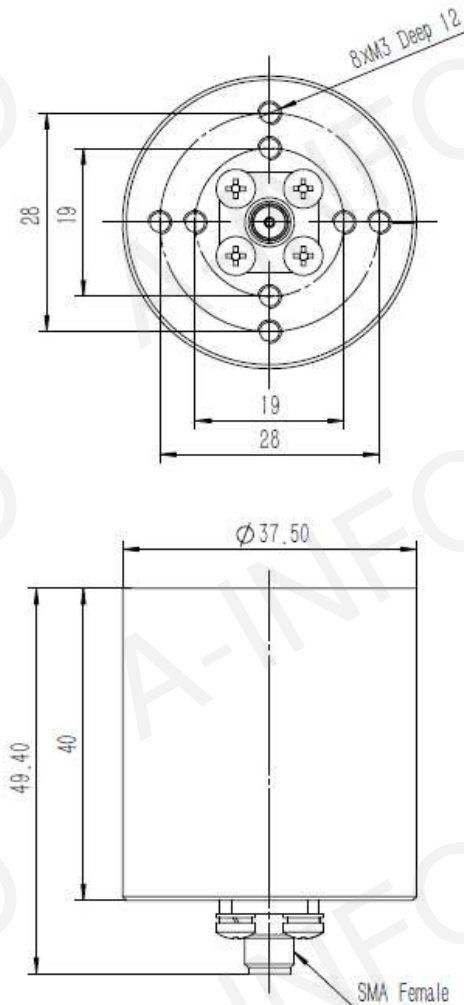

## Test Results

### 1. Gain

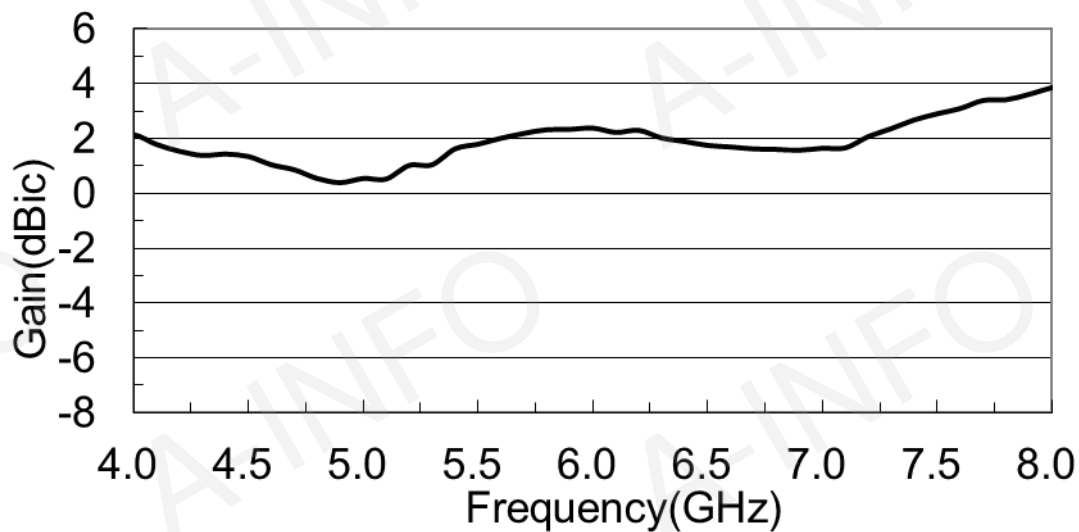

### 2. Antenna Factor

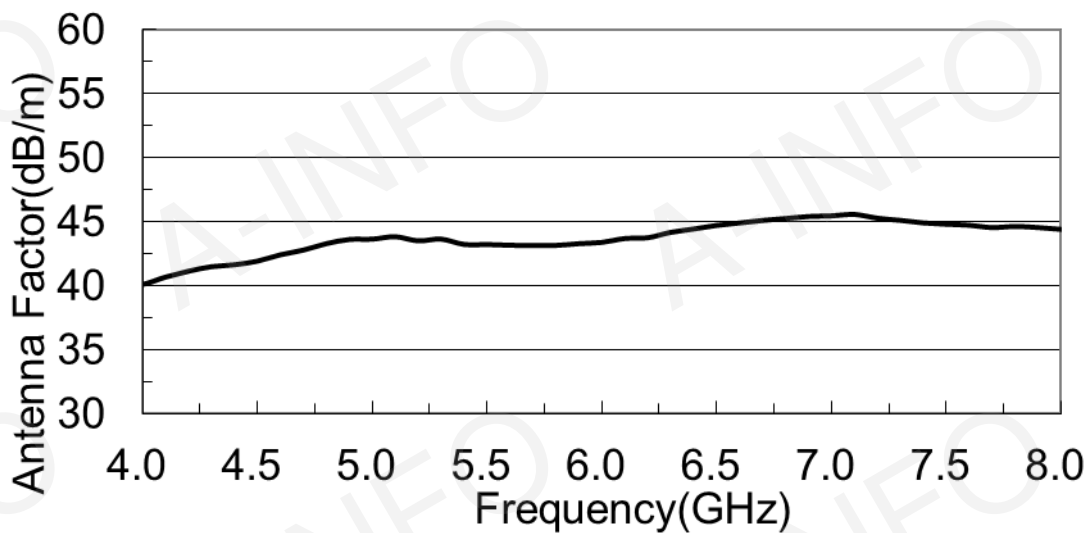

### 3. Axial Ratio

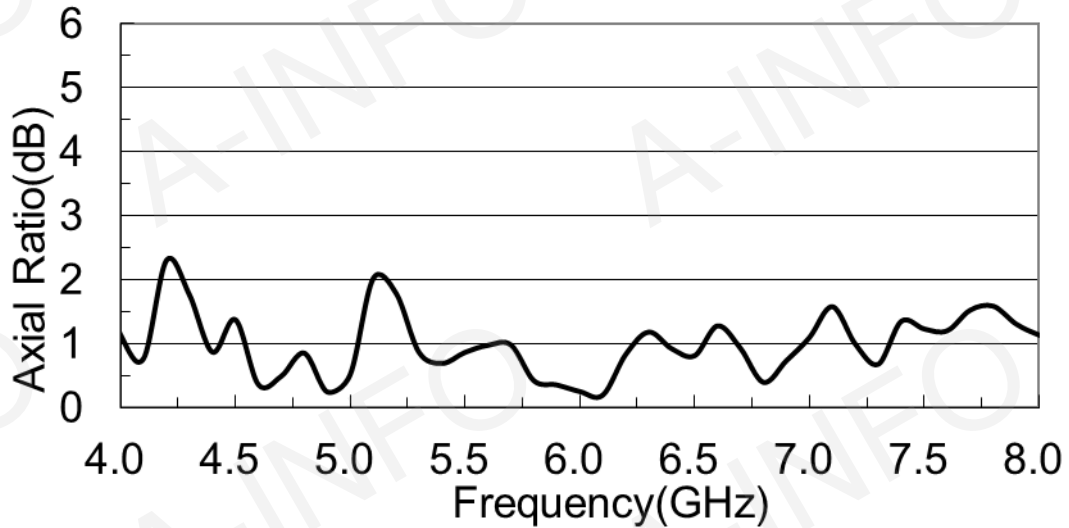

### 4. VSWR

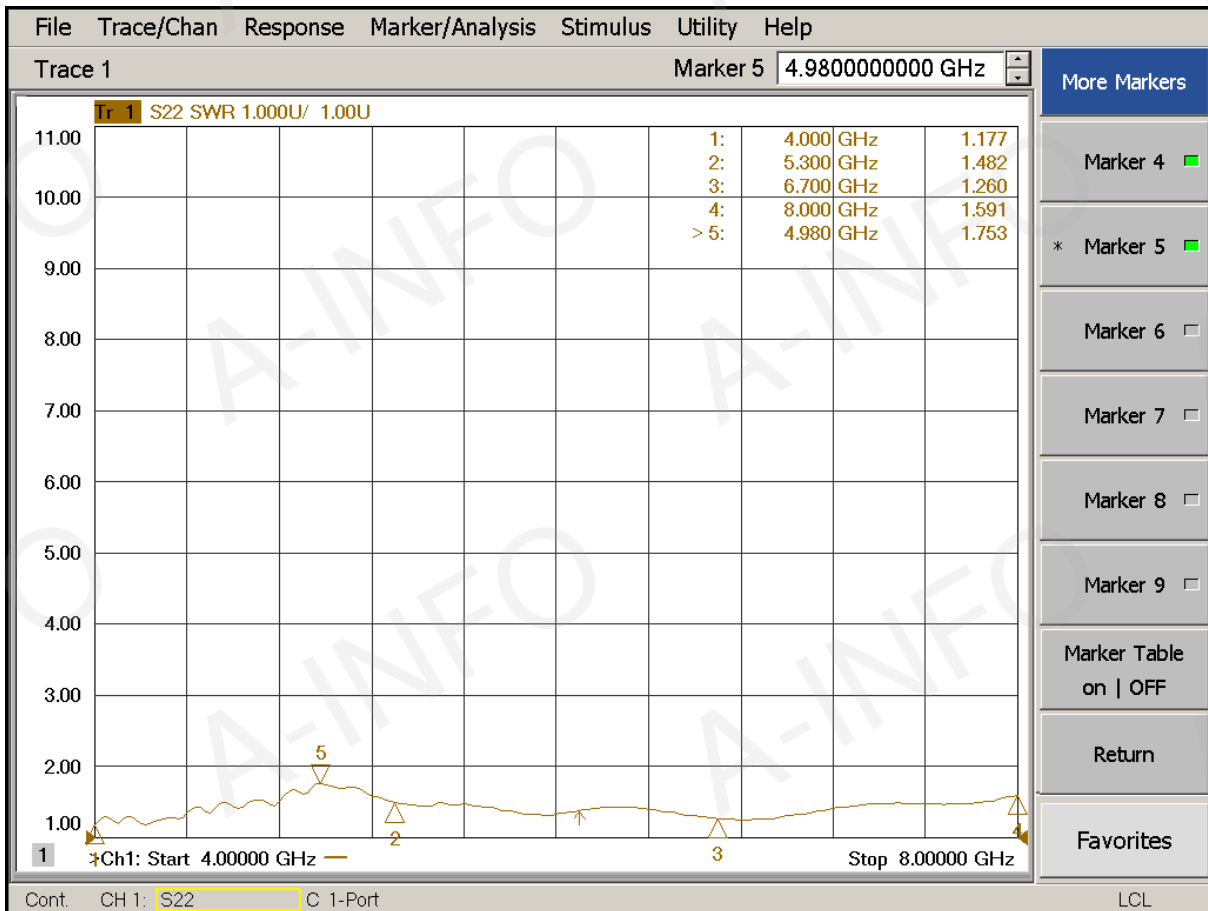

## 5. Pattern

