

PRODUCT DATASHEET

Version 1.0

CGY2183GS/C1

0.1 – 6 GHz Active Mixer

DESCRIPTION

The CGY2183GS/C1 is a high performance GaAs based Active Double Balanced Mixer MMIC.

The CGY2183GS/C1 covers the frequency range of 0.1 GHz to 6 GHz, with a conversion gain of typically 12 dB, and uses an active Gilbert Cell Mixer Structure. It can be used in GPS, Telecommunication, Radar, Instrumentation, and EW applications.

The die is manufactured using OMMIC's 0.18 μm gate length PHEMT Technology ED02AH. The MMIC uses gold bonding pads and backside metallization and is fully protected with Silicon Nitride passivation to obtain the highest level of reliability.

APPLICATIONS

- ▶ Satellite payload
- ▶ GPS Systems
- ▶ Radar
- ▶ Telecommunication
- ▶ Instrumentation

FEATURES

- ▶ RF and LO Range : 0.1 GHz to 6 GHz
- ▶ IF Range : DC – 3 GHz
- ▶ Conversion Gain : 12 dB
- ▶ RF to IF Leakage : -35 dBc
- ▶ LO to IF Isolation : 40 dB
- ▶ Output $P_{1\text{dB}}$: -5 dBm
- ▶ Hermetic Package
- ▶ Tested, Inspected Known Good Die (KGD)
- ▶ Samples Available
- ▶ Demonstration Boards Available
- ▶ Space and MIL-STD Available

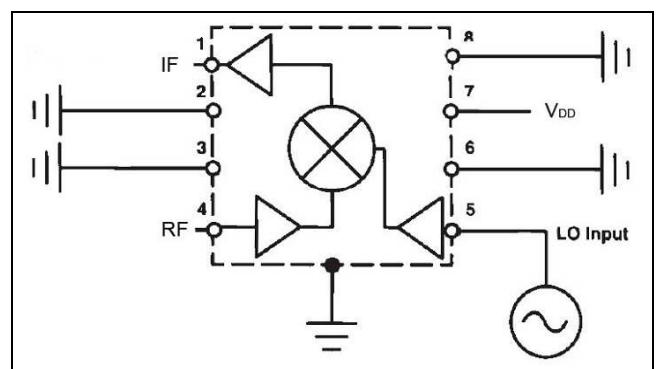

CGY2183GS/C1 Mixer Block Diagram



Revision : 05/12/13

Website : <http://www.ommic.com>

OMMIC

2, Rue du Moulin – BP11 – 94 453
Limeil-Brévannes Cedex – FRANCE

Email : information@ommic.com

LIMITING VALUES

Conditions : $T_{amb} = 25\text{ }^{\circ}\text{C}$ unless otherwise noted

Symbol	Parameter	Conditions	MIN.	MAX.	UNIT
V_D	Supply Voltage			9	V
P_{LO}	Local Oscillator Input Power			0	dBm
P_{RF}	RF Input Power			TBD	dBm
T_{amb}	Ambient temperature		-30	+85	$^{\circ}\text{C}$
T_j	Junction temperature			+150	$^{\circ}\text{C}$
T_{stg}	Storage temperature		-55	+150	$^{\circ}\text{C}$

THERMAL CHARACTERISTICS

Symbol	Parameter	Value	UNIT
$R_{th(j-a)}$	Thermal resistance from junction to ambient ($T_a = 25\text{ }^{\circ}\text{C}$)	TBD	$^{\circ}\text{C/W}$

CHARACTERISTICS

Conditions : $T_{amb} = 25\text{ }^{\circ}\text{C}$ – RF Performance measured on wafer.

Symbol	Parameter	Conditions	MIN.	TYP.	MAX.	UNIT
<i>Unless otherwise specified LO Power = -5 dBm; IF = 30 MHz; RF = 2.2 GHz; Down Converter Mode</i>						
V_{DD}	Supply Voltage			7		V
I_{DD}	Supply Current		17	21	25	mA
BW_{RF}	RF Bandwidth		0.1		6	GHz
BW_{LO}	LO Bandwidth		0.1		6	GHz
BW_{IF}	IF Bandwidth		DC		3	GHz
G_c	Conversion Gain		9	12	15	dB
NF (SSB)	SSB Noise Figure			8		dB
ISO_{RF-IF}	RF to IF Leakage			-35	-30	dBc
ISO_{LO-IF}	LO to IF Isolation		30	40		dB
P_{1dB}	Input 1dBm Compression Point		-7	-5		dBm



Caution : This device is a high performance RF component and can be damaged by inappropriate handling. Standard ESD precautions should be followed. OMMIC document “OM-CI-MV/ 001/ PG” contains more information on the precautions to take.

ON BOARD MEASUREMENTS – CONVERSION GAIN

Conditions : $T_{amb} = 25\text{ }^{\circ}\text{C}$. Typical results are obtained at $V_{DD} = 7\text{ V}$, $R_F = 2.2\text{ GHz}$, $LO = 2.23\text{ GHz}$, and $IF = 30\text{ MHz}$, unless otherwise specified.

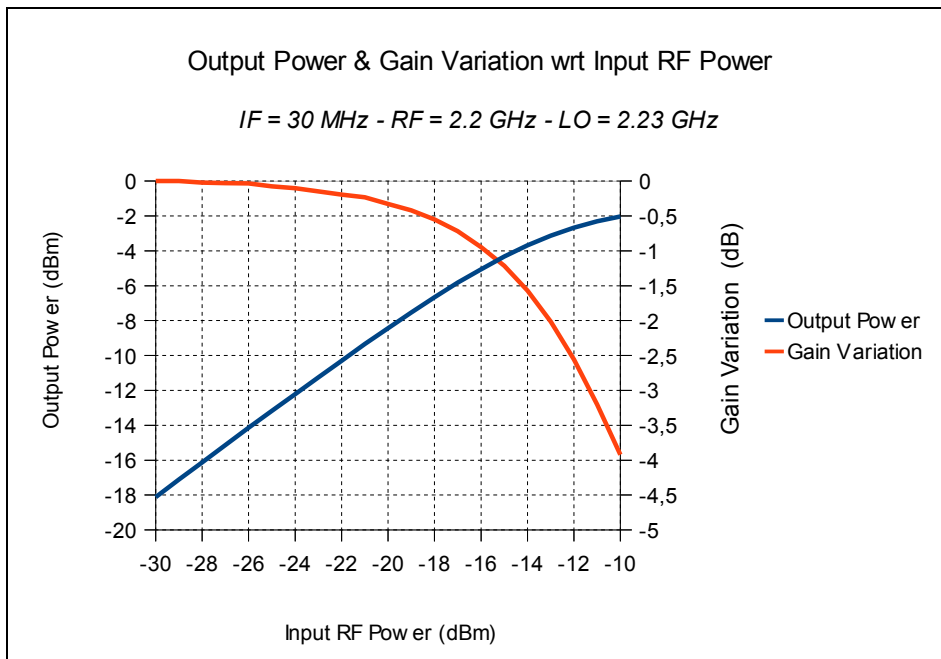
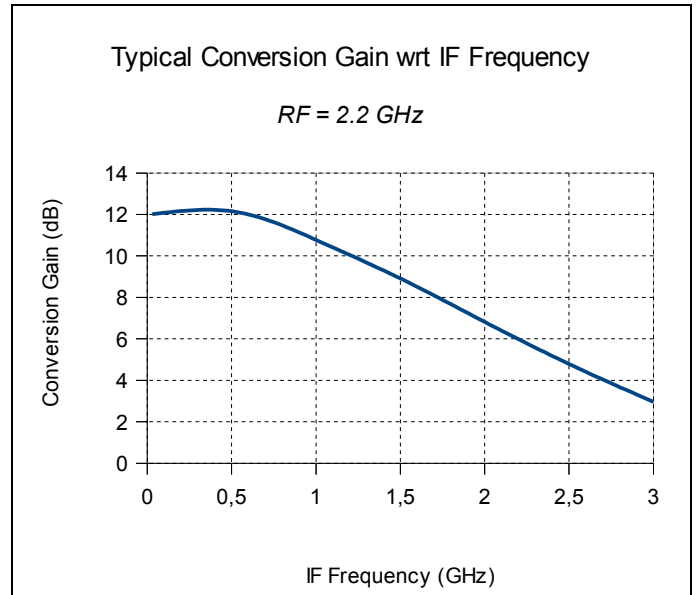
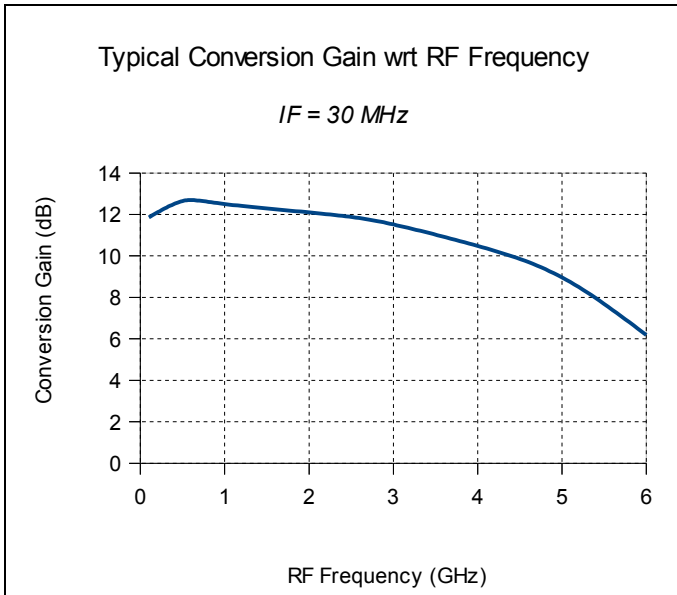

ON BOARD MEASUREMENTS – ISOLATIONS & LEAKAGES

Conditions : $T_{amb} = 25\text{ }^{\circ}\text{C}$. Typical results are obtained at $V_{DD} = 7\text{ V}$, $RF = 2.2\text{ GHz}$, $LO = 2.23\text{ GHz}$, and $IF = 30\text{ MHz}$, unless otherwise specified.

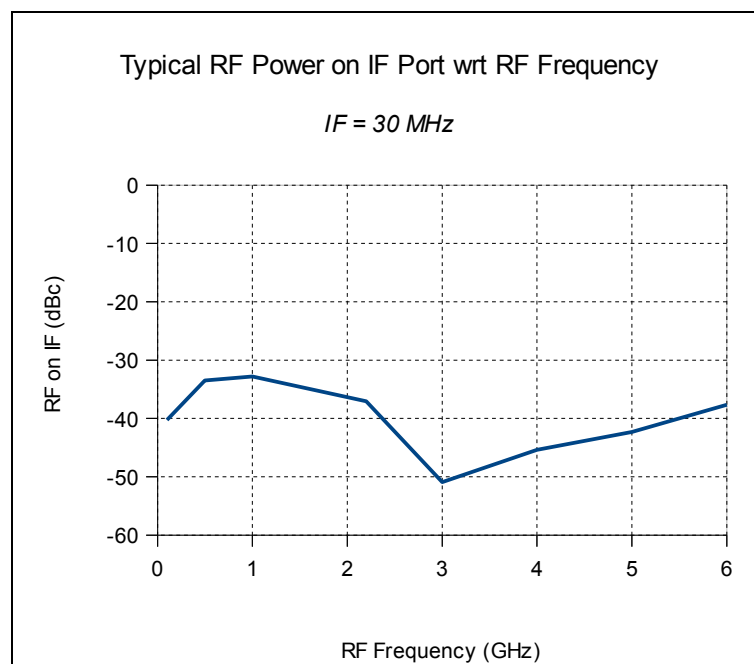
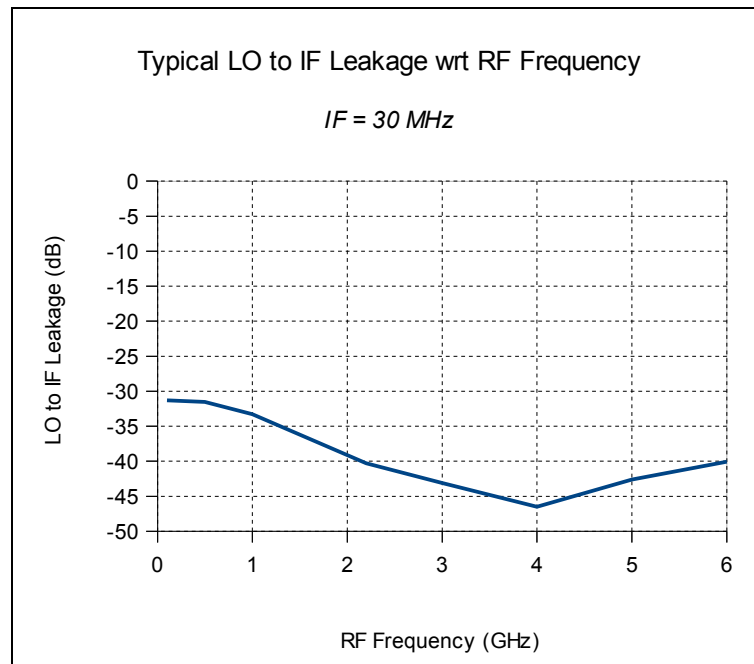

FUNCTIONAL DIAGRAM

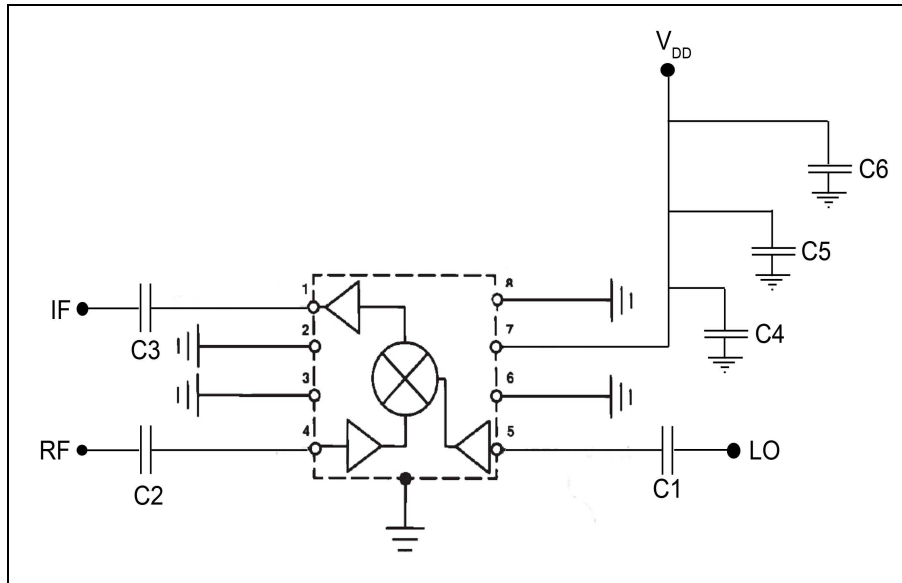

Schematic Diagram of the Mixer Circuit Application Board

Reference	Value	Comment
C1, C2, C3	10 nF	LO, RF, IF DC blocking capacitors
C4	100 pF	DC decoupling capacitor
C5	10 nF	DC decoupling capacitor
C6	47 μ F	DC decoupling capacitor

The RF, LO and IF ports should be suitably decoupled with series DC blocking capacitors (C1,C2,C3) and the DC power supply should be decoupled with a suitable network of parallel capacitors (C4,C5,C6) as shown above. The nominal value of V_{DD} is 8 V.

PIN ASSIGNMENT

Lead	Symbol	Description
1	IF	IF output
2	GND	Ground
3	GND	Ground
4	RF	RF Input
5	LO	LO Input
6	GND	Ground
7	V_{DD}	Positive Supply Voltage
8	GND	Ground

MECHANICAL INFORMATION

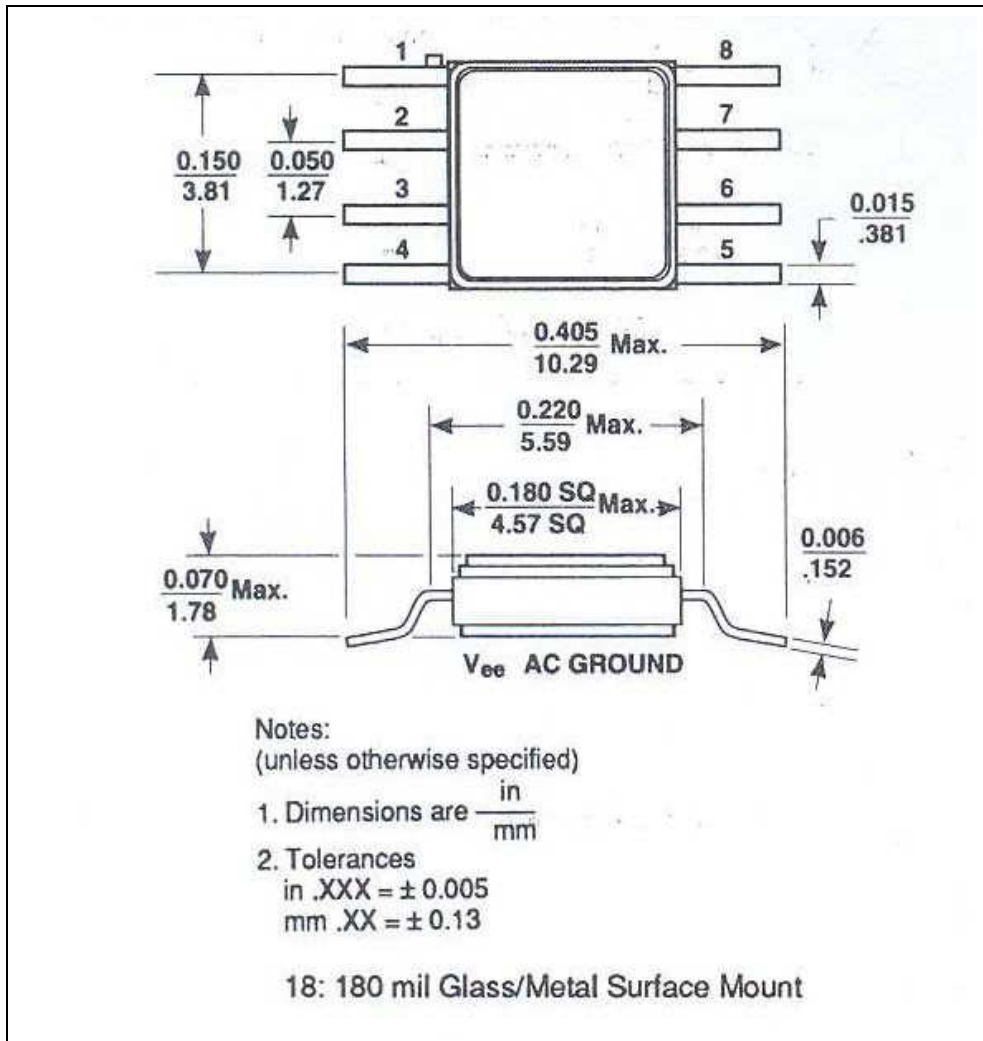

ORDERING INFORMATION

Generic type	Package type	Version	Description
CGY2183GS	Hermetic Package	C1	Active Double Balanced Quad Mixer



DEFINITIONS

Limiting values definition

Limiting values given are in accordance with the Absolute Maximum Rating System (IEC 60134). Stress above one or more of the limiting values may cause permanent damage to the device. These are stress ratings only and operation of the device at these or at any other conditions above those given in the Characteristics sections of the specification is not implied. Exposure to limiting values for extended periods may affect device reliability.

Application information

Applications that are described herein for any of these products are for illustrative purposes only. OMMIC makes no representation or warranty that such applications will be suitable for the specified use without further testing or modification.

DISCLAIMERS

Life support applications

These products are not designed for use in life support appliances, devices, or systems where malfunction of these products can reasonably be expected to result in personal injury. OMMIC's customers using or selling these products for use in such applications do so at their own risk and agree to fully indemnify OMMIC for any damages resulting from such application.

Right to make changes

OMMIC reserves the right to make changes, without notice, in the products, including circuits, standard cells, and/or software, described or contained herein in order to improve design and/or performance. OMMIC assumes no responsibility or liability for the use of any of these products, conveys no licence or title under any patent, copyright, or mask work right to these products, and makes no representations or warranties that these products are free from patent, copyright, or mask work right infringement, unless otherwise specified.