

FEATURES

- -5/-2 dBm P1dB/PSAT
- D-band coverage
- 12 dB conversion loss

DESCRIPTION

gMDR0035 is a subharmonic IQ mixer in the 140-160 GHz frequency band suitable for D-band point-to-point communication, instrumentation, sensing, security and high resolution imaging applications. The mixer works perfectly together with the gXSB0025 ×6 frequency multiplier to form a D-band receiver and transmitter chain. The mixer has high image rejection, low input/output return loss and flat conversion response.

TYPICAL APPLICATIONS

- Point-to-point communication
- Instrumentation
- Fiber over radio
- Imaging
- Sensing / security

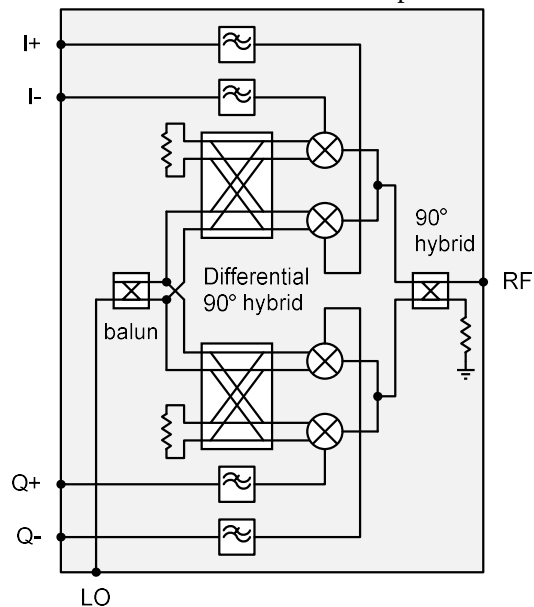

Figure 1. Block diagram of the subharmonic mixer.

ELECTRICAL PERFORMANCE

Table 1. Electrical performance as modulator at $T_A=25^\circ\text{C}$

Parameter	Min	Typ	Max	Unit
RF frequency	140		170	GHz
IF frequency	DC		6	GHz
LO frequency	70		85	GHz
LO input power		15		dBm
LO multiplication factor		2		
Conversion loss ¹		12		dB
2×LO to RF port isolation ²	35			dB
Image rejection ratio (IRR)		15		dB
P1dB		-5		dBm
PSAT		TBD		dBm
OIP3		TBD		dBm
IIP3		TBD		dBm
OIP2	TBD			dBm
IIP2	TBD			dBm
Out of band spurioues			TBD	dBm
NF			TBD	dB
RF return loss	10			dB
IF return loss	10			dB
LO return loss	10			dB
Power consumption		0		mW

¹ Gain temperature coefficient is 0.005 dB/C.

² Apply I+, I-, Q+ and Q- input DC offset voltage for LO cancellation.

MEASURED PERFORMANCE UP-CONVERSION

The chip has been measured on-wafer using CW and 2-tone input test signals. The modulator uses typical bias settings if not specified differently.

Table 2. Test conditions

Parameter	Setting
IF input power	-10 dBm/tone
IF input frequency	1 GHz
Frequency separation	10 MHz
LO input frequency	82.5 GHz
Temperature	+25°C

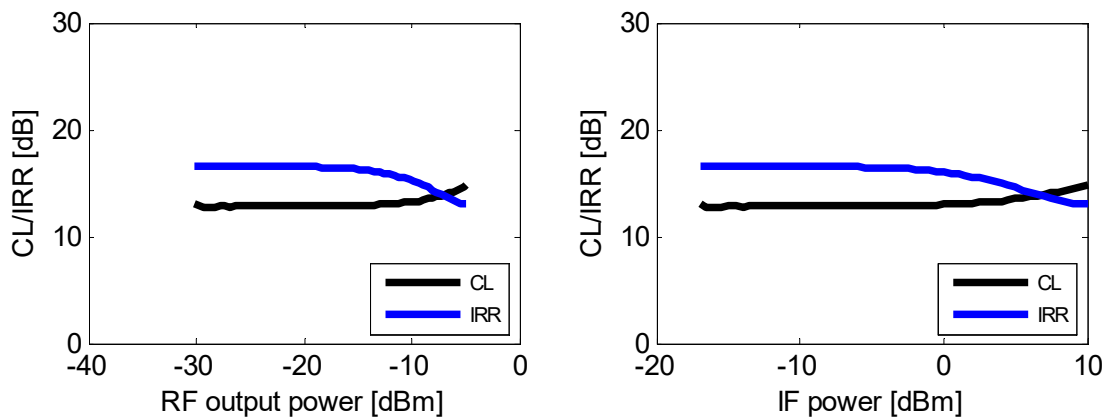

Figure 2. (Left): CL and IRR vs RF output power at 145 GHz and VG=-1.3 V. (Right): CL and IRR vs IF input power at 145 GHz and VG=-1.3 V. (CW measurement)

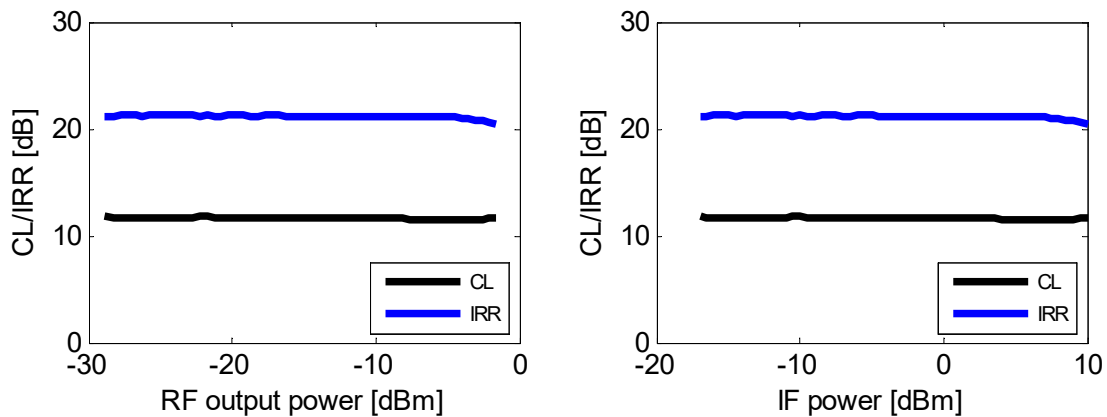

Figure 3. (Left): CL and IRR vs RF output power at 155 GHz and VG=-1.5 V. (Right): CL and IRR vs IF input power at 155 GHz and VG=-1.5 V. (CW measurement)

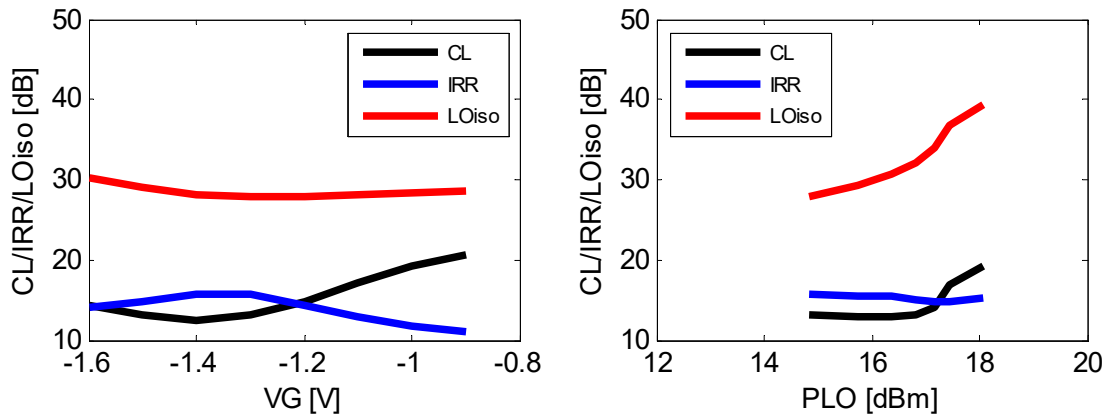

Figure 4. (Left): CL, IRR and 2xLO suppression vs VG_MIX at 145 GHz. (Right): CL, IRR and 2xLO suppression vs LO input power at VG=-1.3 V at 145 GHz. (CW measurement)

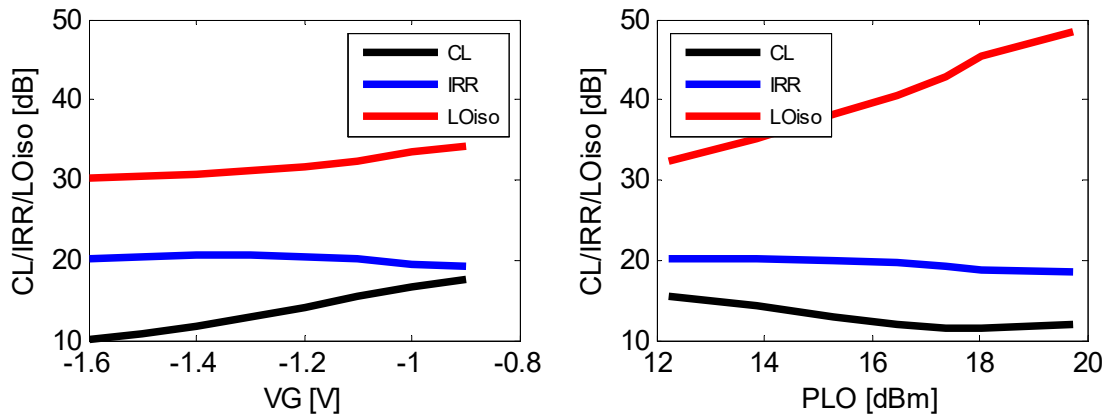

Figure 5. (Left): CL, IRR and 2xLO suppression vs VG_MIX at 155 GHz and PLO=16 dBm. (Right): CL, IRR and 2xLO suppression vs LO input power at VG=-1.5 V at 155 GHz. (CW measurement)

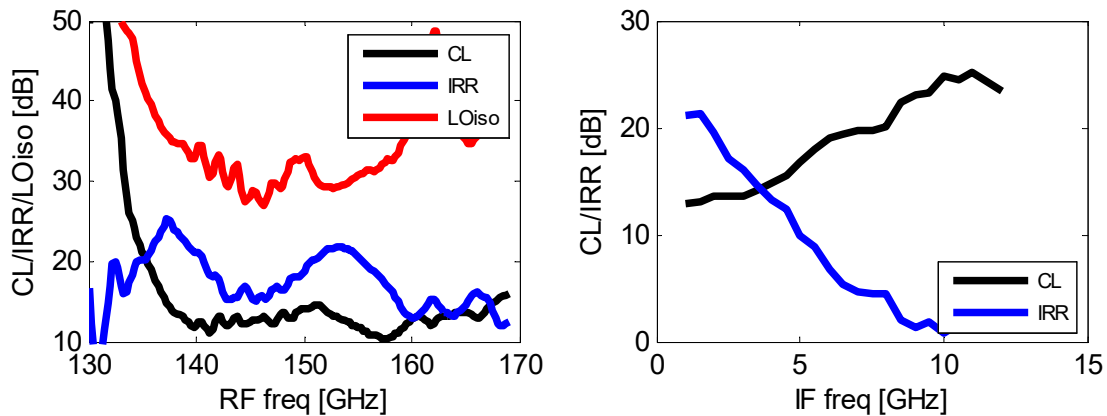

Figure 6. (Left): CL, IRR and 2xLO suppression vs RF frequency at VG=-1.4 V. (Right): CL, IRR and 2xLO suppression vs IF frequency (LO frequency is fixed at 155 GHz). (CW measurement)

RECOMMENDED OPERATING CONDITIONS

Bias should first be applied to the gates (VG...) followed by the drains (VD...). The gate voltages must be adjusted within the min/max range indicated in Table 3-5 to obtain the specified drain currents. The drain currents are stated with on input signal.

Table 3. Electrical settings on connector P1

Connector P1	Pad No.	Bias settings (V/mA)			I/O
		Min	Typ	Max	
VG_MIX ^[3]	1	-1.7	-1.4	-1.1	Input
GND	2				Ground
NC	3				NC

Table 4. Electrical settings on connector P2

Connector P2	Pad No.	Interface	I/O
GND	4		Ground
RF	5	$Z_0 = 50 \text{ Ohm}$, AC coupled	Output/ Input
GND	6		Ground

Table 5. Electrical settings on connector P3

Connector P3	Pad No.	Interface	Function
GND	7		Ground
LO	8	$Z_0 = 50 \text{ Ohm}$, AC coupled	Input
GND	9		Ground

³ Optimum mixer gate bias occurs close to pinch-off and varies between wafers.

Table 6. Electrical settings on connector P4

Connector P4	Pad No.	Interface	Function
GND	10		Ground
I+	11	$Z_0 = 100$ Ohm differential impedance, DC coupled	Input/ Output
I-	12		
GND	13		Ground
Q+	14	$Z_0 = 100$ Ohm differential impedance, DC coupled	Input/ Output
Q-	15		
GND	16		Ground

ABSOLUTE MAXIMUM RATINGS

Table 7. Absolute maximum ratings

Gate-source voltage	-2 to +0.7 V
Drain-source voltage	4.5 V
Gate-drain breakdown voltage	8 V
RF input power	+20 dBm
Operating temperature	-40 to + 85°C
LO input power	+20 dBm
Storage temperature	-65 to +150°C

OUTLINE DRAWING

Mechanical drawing with pad locations is also available in dxf-file format on the web. The substrate thickness is 50 μm (GaAs).

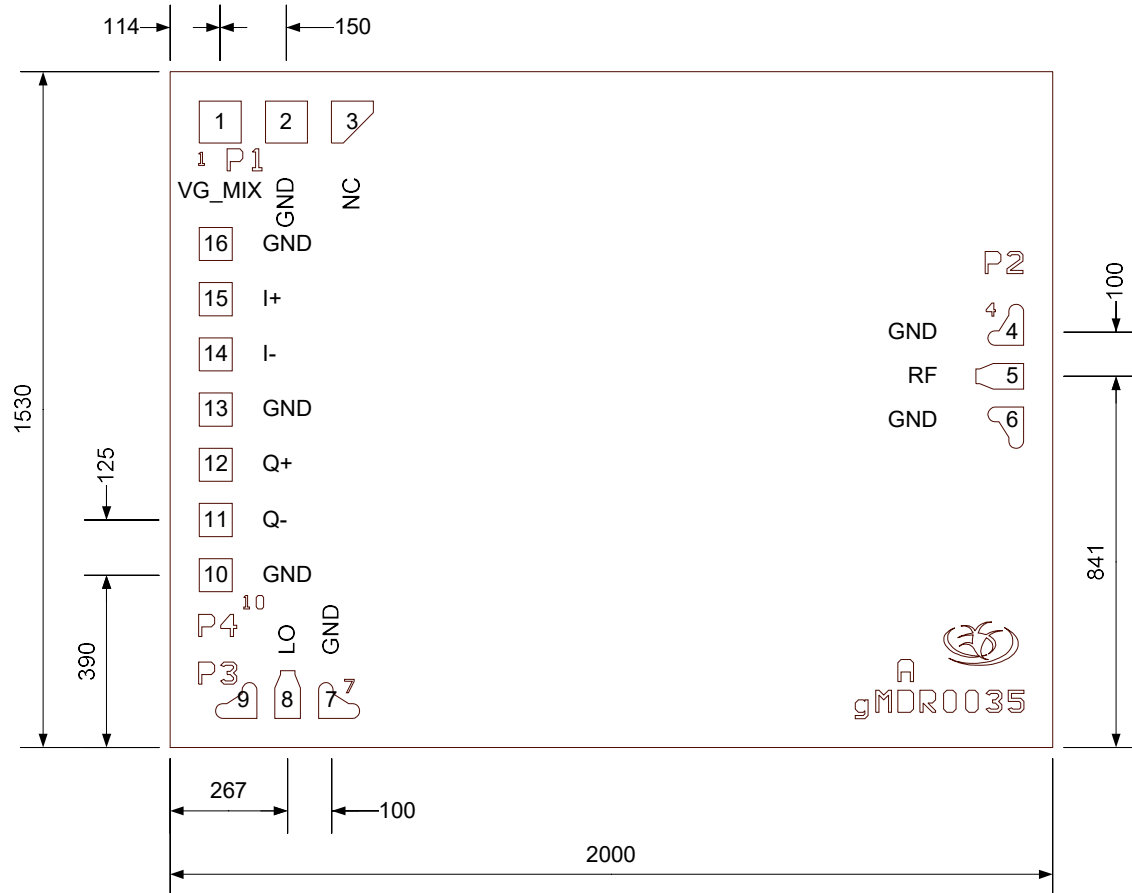

Figure 7. Outline drawing of the MMIC. Dimensions are in μm .