

▪ **Outline Dimension Drawing**

Dimensions: mm[inch]

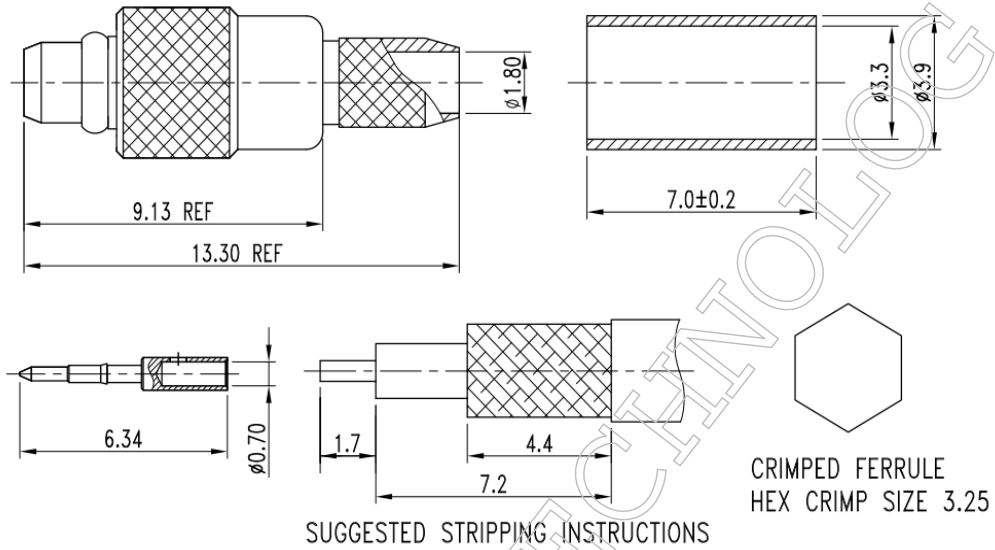

▪ **Material Specification**

Description	Material	Plating
Body*2	Brass	Gold
Contact	Brass	Gold
Dielectric	PTFE	
Ferrule	Brass	Gold
Retaining Ring	BeCu	Gold

In the effort to improve our products, we reserve the right to make changes judged to be necessary



▪ **Electrical Specification**

Description			Description		
Impedance	50	Ω	Insulation Resistance	500	MΩ Min.
Frequency	6	GHz	Inner Contact Resistance	5	mΩ Max.
VSWR	1.25	Max.	Outer Contact Resistance	2.5	mΩ Max.
Insertion Loss	0.15	dB Max.			
Voltage Rating	170	Vrms Max.			
Dielectric Withstanding Voltage	500	Vrms Max.			

▪ **Mechanical Specification**

Description			Description		
Center Contact			Recommended Torque	N/A	in. lbs
Axial Force-Mating End	2	lbs.			
Axial Force-Opposite End	N/A	lbs.			
Connector Durability	500	cycles			
Weight	N/A	g			

▪ **Environmental Specification**

Description		
Temperature Min.	-65	°C
Temperature Max.	165	°C
Hermetic Seal	N/A	

In the effort to improve our products, we reserve the right to make changes judged to be necessary