

▪ **Outline Dimension Drawing**

Dimensions: mm[inch]

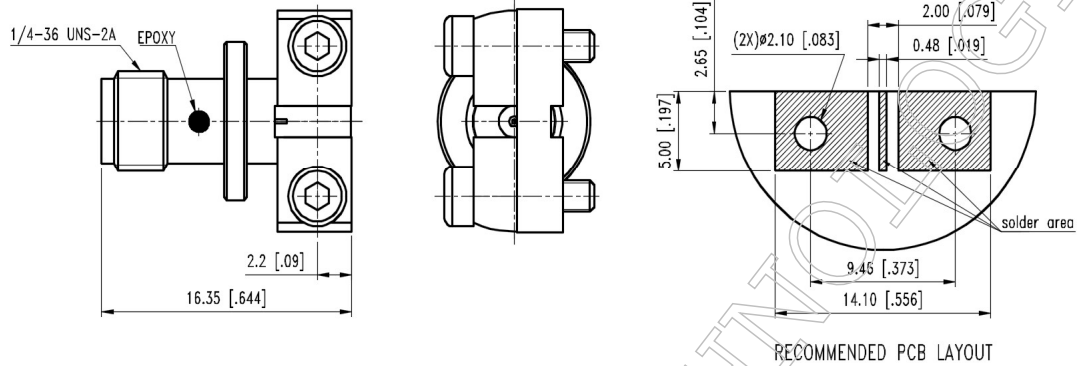

▪ **Material Specification**

Description	Material	Plating
Body	Stainless steel	Passivate
Contact	BeCu	Gold
Dielectric	PTFE	
Adjustable Block	Stainless steel	Passivate
Screw	Stainless steel	

In the effort to improve our products, we reserve the right to make changes judged to be necessary



▪ **Electrical Specification**

Description		Description	
Impedance	50 Ω	Insulation Resistance	5000 MΩ Min.
Frequency	18 GHz	Inner Contact Resistance	6 mΩ Max.
VSWR	1.25 Max.	Outer Contact Resistance	2 mΩ Max.
Insertion Loss	0.25 dB Max.		
Voltage Rating	500 Vrms Max.		
Dielectric Withstanding Voltage	1000 Vrms Max.		

▪ **Mechanical Specification**

Description		Description	
Center Contact		Recommended Torque	7~9 in. lbs
Axial Force-Mating End	6 lbs.	Coupling Nut Retention	N/A lbs. Min.
Axial Force-Opposite End	6 lbs.		
Connector Durability	500 cycles		
Weight	N/A g		

▪ **Environmental Specification**

Description		Description	
Temperature Min.	-65 °C		
Temperature Max.	165 °C		
Hermetic Seal	N/A		

In the effort to improve our products, we reserve the right to make changes judged to be necessary