

▪ **Outline Dimension Drawing**

Dimensions: mm[inch]

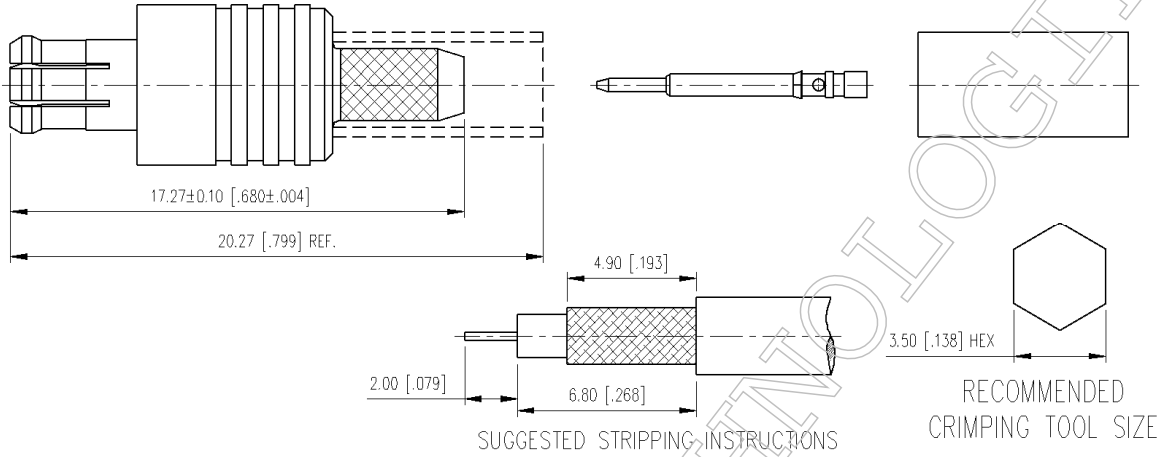

▪ **Material Specification**

Description	Material	Plating
Body	Brass	Gold
Outer Contact	BeCu	Gold
Pin	Brass	Gold
Dielectric	PTFE	
Ferrule	Brass	Gold

In the effort to improve our products, we reserve the right to make changes judged to be necessary



▪ **Electrical Specification**

Description			Description		
Impedance	75	Ω	Insulation Resistance	1000	MΩ Min.
Frequency	2	GHz	Inner Contact Resistance	5	mΩ Max.
VSWR	1.25	Max.	Outer Contact Resistance	2.5	mΩ Max.
Insertion Loss	0.1	dB Max.			
Voltage Rating	250	Vrms Max.			
Dielectric Withstanding Voltage	500	Vrms Max.			

▪ **Mechanical Specification**

Description		
Center Contact Retention	N/A	lbs. Min.
Engagement Force	5.6	lbs. Max.
Disengagement Force	4.5	lbs. Max.
Connector Durability	500	matings min.
Weight	N/A	g

▪ **Environmental Specification**

Description		
Temperature Min.	-55	°C
Temperature Max.	155	°C
Hermetic Seal	N/A	

In the effort to improve our products, we reserve the right to make changes judged to be necessary