

▪ **Outline Dimension Drawing**

Dimensions: mm[inch]

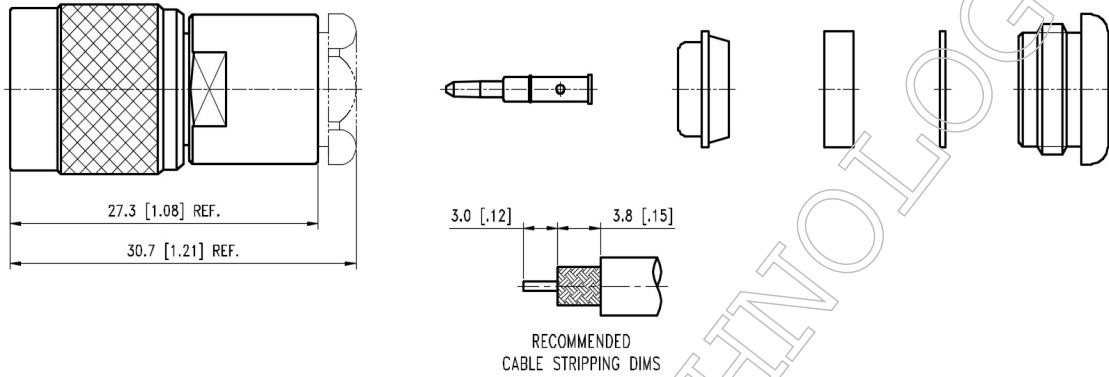

▪ **Material Specification**

Description	Material	Plating
Body	Brass	Nickel
Contact	Brass	Gold
Dielectric	PTFE	
End Nut	Brass	Nickel
Clamp	Brass	Nickel
Gasket	S.I.R	Red
Washer	Brass	Nickel
Shell	Brass	Nickel
Washer	Brass	Nickel
Open Washer	Brass	Nickel
Gasket	S.I.R	Red
Washer	Brass	Nickel

In the effort to improve our products, we reserve the right to make changes judged to be necessary



▪ **Electrical Specification**

Description		Description	
Impedance	50 Ω	Insulation Resistance	5000 MΩ Min.
Frequency	3 GHz	Inner Contact Resistance	3.0 mΩ Max.
VSWR	1.3 Max.	Outer Contact Resistance	2.0 mΩ Max.
Insertion Loss	0.15 dB Max.		
Voltage Rating	500 Vrms Max.		
Dielectric Withstanding Voltage	1500 Vrms Max.		

▪ **Mechanical Specification**

Description		Description	
Center Contact		Recommended Torque	10~12 in. lbs
Axial Force-Mating End	N/A lbs.	Coupling Nut Retention	100 lbs. Min.
Axial Force-Opposite End	N/A lbs.		
Connector Durability	500 cycles		
Weight	N/A g		

▪ **Environmental Specification**

Description	
Temperature Min.	-65 °C
Temperature Max.	165 °C
Hermetic Seal	N/A

In the effort to improve our products, we reserve the right to make changes judged to be necessary