

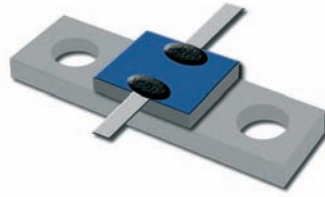

Standards
NF C 96-315
MIL-DTL-3933

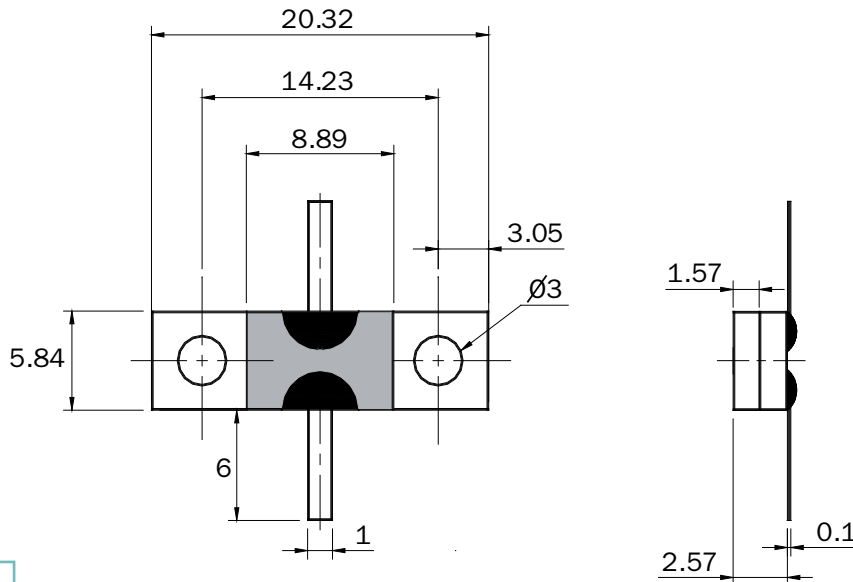

Substrate	AIN
Resistive film	Thick film
Tab	Ag
Protection film	Epoxy
Mounting flange/Plating	Cu/Ni
Tab Attachment	Brazed with epoxy encapsulation

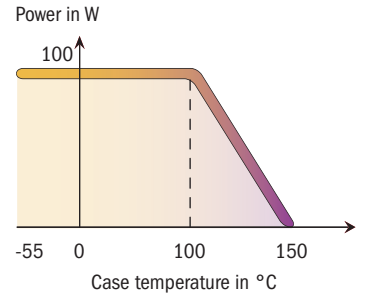

Dimensions in mm

P/N	Attenuation* (dB)	Frequency (GHz)	Power (W)	Impedance ($\Omega \pm 5\%$)	Max VSWR	Accuracy $\pm \Delta\alpha$ (dB)
16-6839	1	3	100	50	1.20	0.3
16-6840	2	3	100	50	1.20	0.3
16-6725	20	2.5	100	50	1.20	0.5
16-6726	30	2.5	100	50	1.20	1.5

mm	inch
0.1	0.004
1	0.040
1.57	0.062
2.57	0.101
3	0.118
3.05	0.120
5.84	0.230
6	0.236
8.89	0.350
14.23	0.560
20.32	0.800

* Others values on request

