

▪ **Outline Dimension Drawing**

Dimensions: mm[inch]

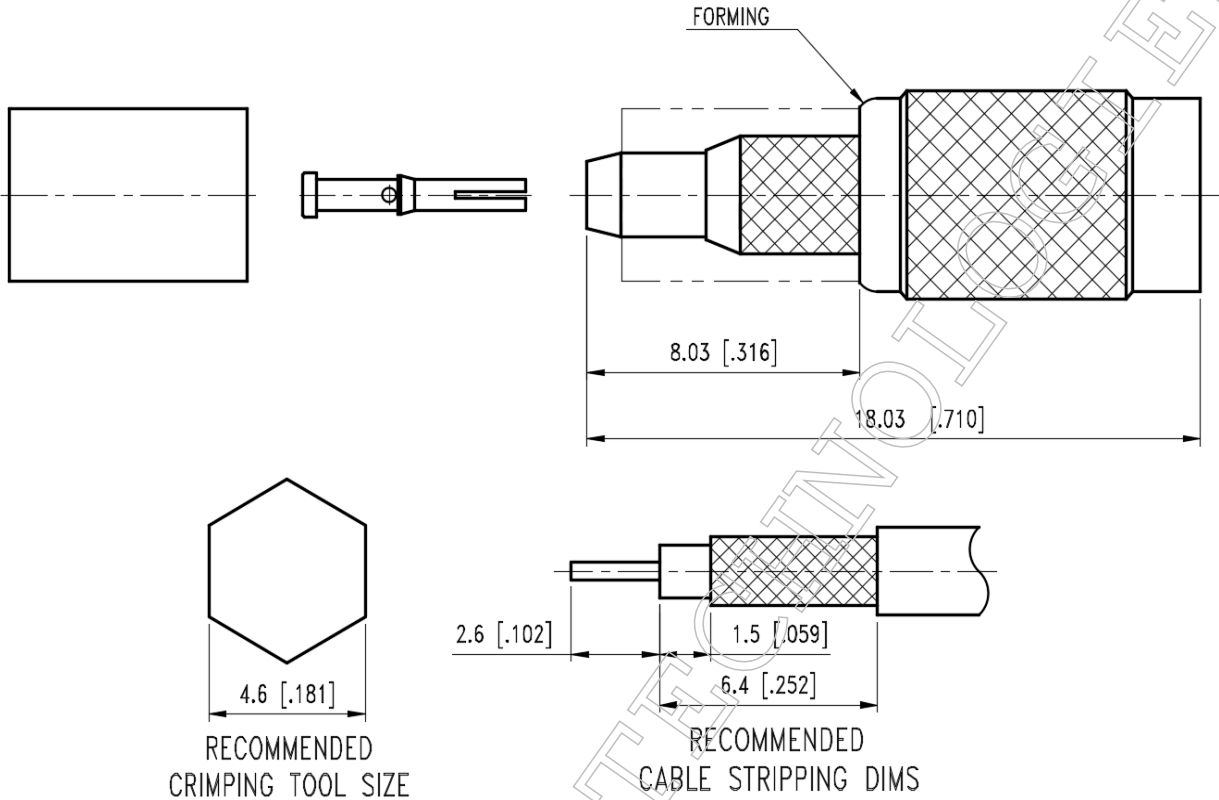

▪ **Material Specification**

Description	Material	Plating
Body*2	Brass	Nickel
Contact	P.Bronze	Gold
Dielectric	PTFE	
Ferrule	Brass	Nickel
Retaining Ring	BeCu	Nickel

In the effort to improve our products, we reserve the right to make changes judged to be necessary



▪ **Electrical Specification**

Description			Description		
Impedance	50	Ω	Insulation Resistance	1000	MΩ Min.
Frequency	4	GHz	Inner Contact Resistance	5	mΩ Max.
VSWR	1.25	Max.	Outer Contact Resistance	2.5	mΩ Max.
Insertion Loss	0.2	dB Max.	Voltage Rating	335	Vrms Max.
Dielectric Withstanding Voltage	750	Vrms Max.			

▪ **Mechanical Specification**

Description			Description		
Center Contact			Recommended Torque	N/A	in. lbs
Axial Force-Mating End	N/A	lbs.	Engagement Force	14.0	lbs Max.
Axial Force-Opposite End	N/A	lbs.	Disengagement Force	4.0	lbs Min.
Connector Durability	500	cycles			
Weight	N/A	g			

▪ **Environmental Specification**

Description		
Temperature Min.	-65	°C
Temperature Max.	165	°C
Hermetic Seal	N/A	

In the effort to improve our products, we reserve the right to make changes judged to be necessary