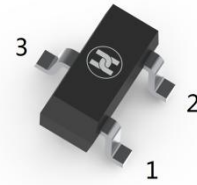
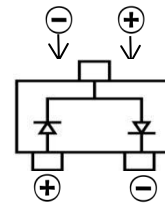

**SCHOTTKY BARRIER DIODE**
**FEATURES**

- Low Forward Voltage
- Fast Switching
- Surface Mount device
- For General Purpose Switching Applications

**SOT-23**

**MECHANICAL DATA**

- Case: SOT-23
- Case Material: Molded Plastic. UL flammability
- Classification Rating: 94V-0
- Weight: 0.013 grams (approximate)
- Marking:CG

**MAXIMUM RATINGS (T<sub>A</sub> = 25°C unless otherwise noted)**

Parameter	Symbol	Value	Unit
Reverse Voltage	V <sub>R</sub>	70	V
Forward Current	I <sub>F</sub>	70	mA
Non-Repetitive Peak Forward Surge Current @ t = 8.3 ms	I <sub>FSM</sub>	100	mA
Power Dissipation	P <sub>D</sub>	200	mW
Thermal Resistance From Junction To Ambient	R <sub>θJA</sub>	500	°C/W
Junction Temperature	T <sub>J</sub>	125	°C
Storage Temperature	T <sub>STG</sub>	-55 ~+150	°C

**ELECTRICAL CHARACTERISTICS (T<sub>A</sub> = 25°C unless otherwise specified)**

Parameter	Symbol	Min	Max	Unit	Conditions
Reverse breakdown voltage	V <sub>(BR)</sub>	70		V	I <sub>R</sub> =10uA
Reverse voltage Leakage current	I <sub>R</sub>		100	nA	V <sub>R</sub> =50V
Forward voltage	V <sub>F1</sub>		0.41	V	I <sub>F1</sub> =1 mA
	V <sub>F2</sub>		1	V	I <sub>F2</sub> =15mA
Diode capacitance	C <sub>D</sub>		2	pF	V <sub>R</sub> =0V,f=1MHz
Reverse recovery time	T <sub>rr</sub>		5	nS	I <sub>F</sub> =I <sub>R</sub> =10mA I <sub>rr</sub> =0.1×I <sub>R</sub> R <sub>L</sub> =100Ω

SCHOTTKY BARRIER DIODE

Typical Characteristics

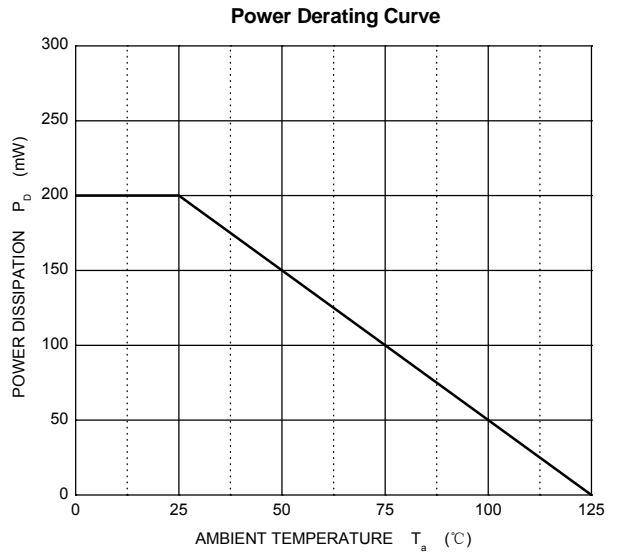
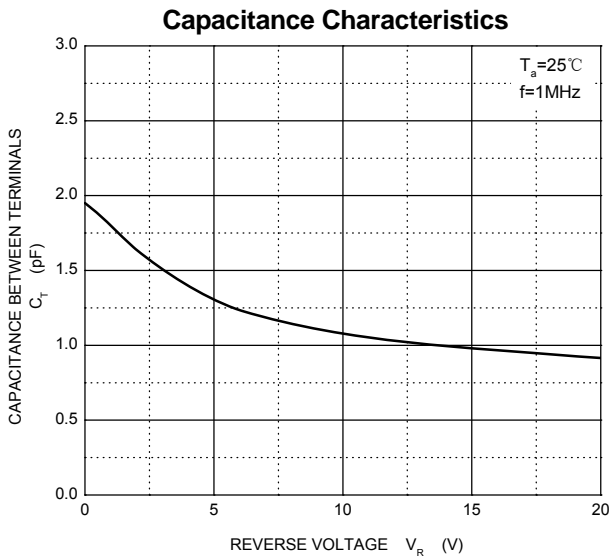
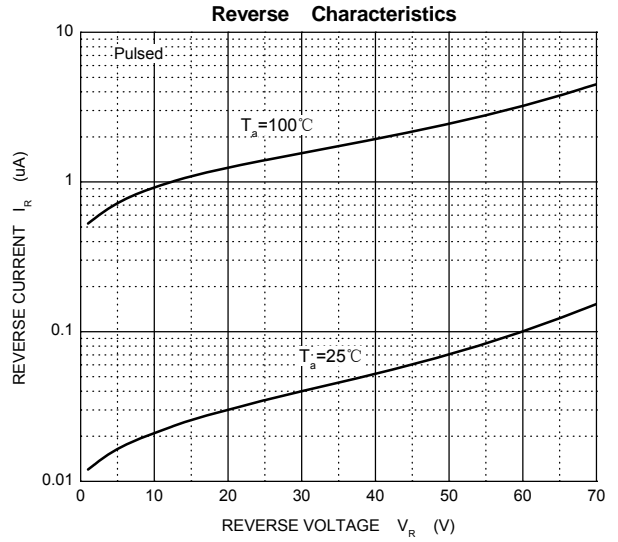
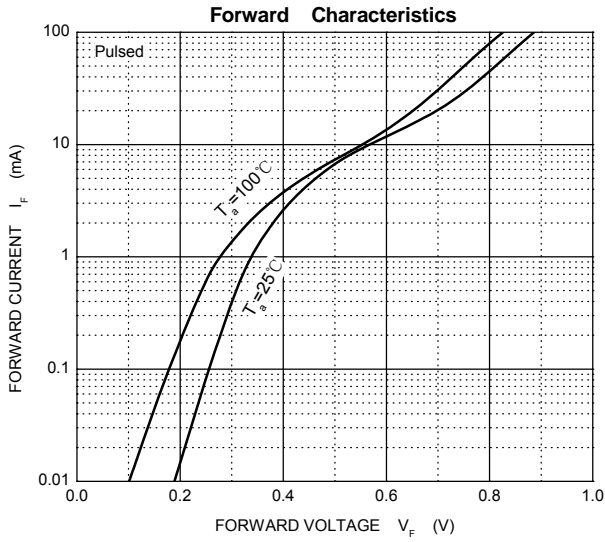

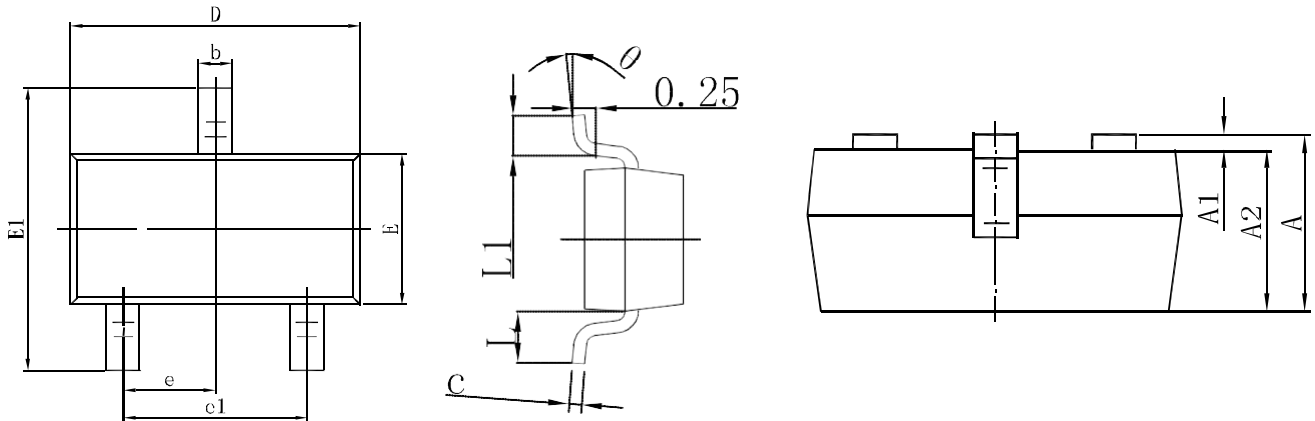
**SCHOTTKY BARRIER DIODE**
**SOT-23 Package Outline Dimensions**

Symbol	Dimensions In Millimeters		Dimensions In Inches	
	Min.	Max.	Min.	Max.
A	0.900	1.150	0.035	0.045
A1	0.000	0.100	0.000	0.004
A2	0.900	1.050	0.035	0.041
b	0.300	0.500	0.012	0.020
c	0.080	0.150	0.003	0.006
D	2.800	3.000	0.110	0.118
E	1.200	1.400	0.047	0.055
E1	2.250	2.550	0.089	0.100
e	0.950 TYP		0.037 TYP	
e1	1.800	2.000	0.071	0.079
L	0.550 REF		0.022 REF	
L1	0.300	0.500	0.012	0.020
$\theta$	0°	8°	0°	8°

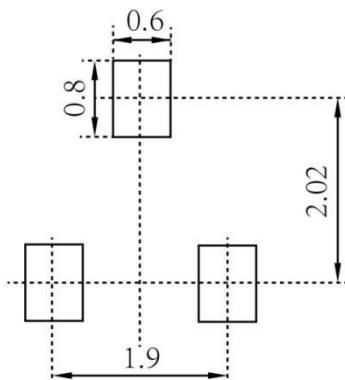
**SOT-23 Suggested Pad Layout**

**Note:**

1. Controlling dimension: in millimeters
2. General tolerance:  $\pm 0.05\text{mm}$
3. The pad layout is for reference purposes only

SCHOTTKY BARRIER DIODE

**SOT-23 Tape and Reel**

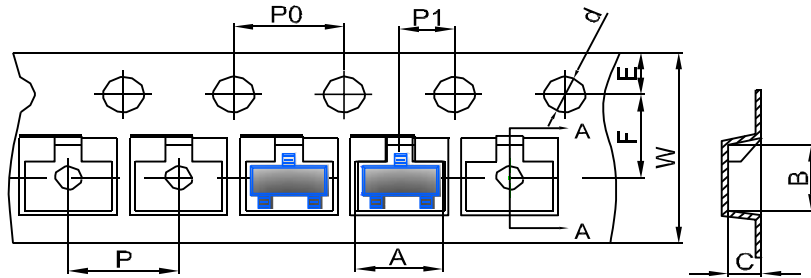
**SOT-23 Embossed Carrier Tape**



DIMENSIONS ARE IN MILLIMETER										
TYPE	A	B	C	d	E	F	P0	P	P1	W
SOT-23	3.15	2.77	1.22	Ø1.50	1.75	3.50	4.00	4.00	2.00	8.00
TOLERANCE	±0.1	±0.1	±0.1	±0.1	±0.1	±0.1	±0.1	±0.1	±0.1	±0.1

**SOT-23 Tape Leader and Trailer**

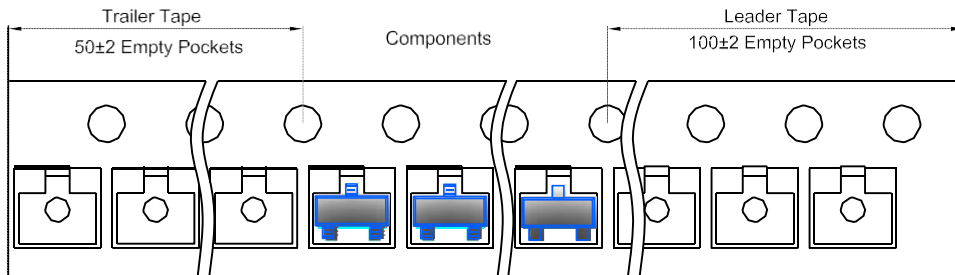

**SOT-23 Reel**

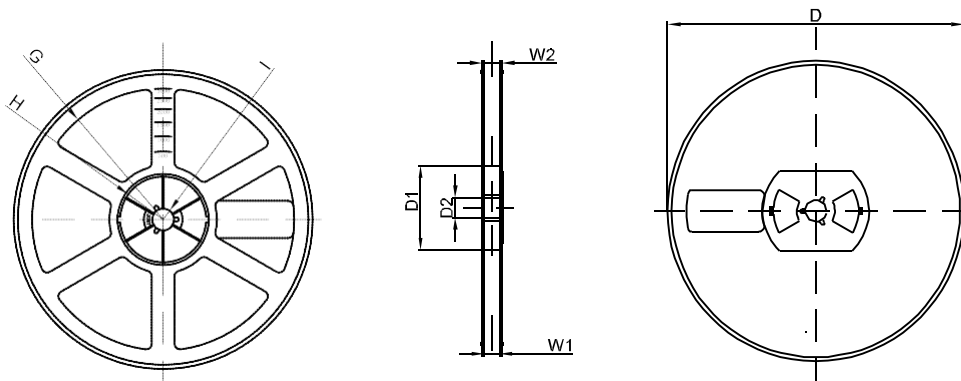

DIMENSIONS ARE IN MILLIMETER								
REEL OPTION	D	D1	D2	G	H	I	W1	W2
7" DIA	Ø178	54.40	13.00	R78	R25.60	R6.50	9.50	12.30
TOLERANCE	±2	±1	±1	±1	±1	±1	±1	±1