

## 2-22GHz LNA with AGC

### GaAs Monolithic Microwave IC

#### Description

The CHA3024-99F is a distributed Low Noise Amplifier with Adjustable Gain Control (AGC) which operates between 2 and 22GHz.

It is designed for a wide range of applications, such as electronic warfare, X and Ku Point to Point Radio, and test instrumentation.

The circuit is manufactured using a 0.15 $\mu$ m gate length pHEMT process, with via holes through the substrate, air bridges and optical gate lithography.

The part is supplied as bare die and input and output RF accesses are matched to 50 ohms.

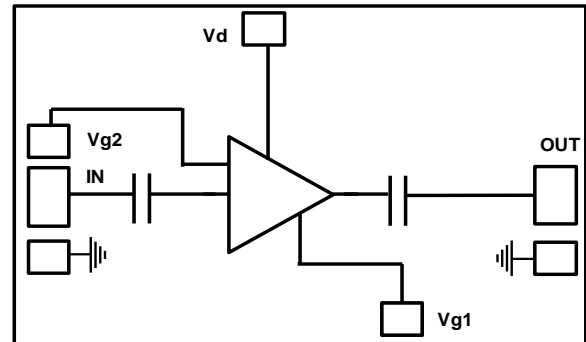

#### Main Features

- Broadband performances: 2-22GHz
- Typical Linear Gain: 15dB
- Up to 30 dB adjustable gain with Vg2
- P<sub>1dB</sub>: 18dBm
- P<sub>sat</sub>: 20dBm
- OIP3: 30dBm
- Typical Noise Figure: 3dB
- DC bias: Vd=5V@Id=100mA, Vg1=-0.3V and Vg2=1.7V.
- Chip dimensions: 3.04 x 1.73 x 0.1mm

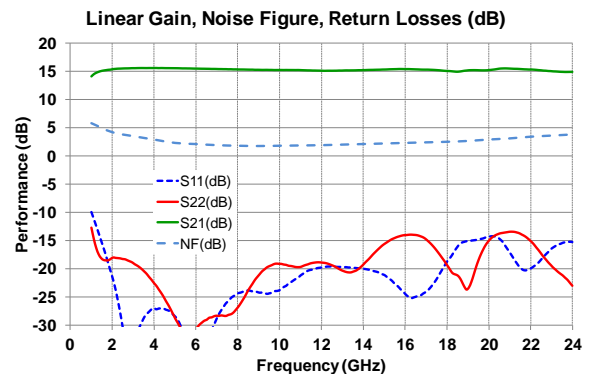

#### Main Electrical Characteristics

T<sub>amb</sub>. = +25°C

Symbol	Parameter	Min	Typ	Max	Unit
Freq	Frequency range	2		22	GHz
Gain	Linear Gain		15		dB
NF	Noise Figure		3		dB
P <sub>1dB</sub>	Output Power @1dB gain comp.		18		dBm

## Electrical Characteristics

Tamb. = +25°C, Vg1 to be set in order to have Idq = 100mA, Vg2 = 1.7V

Symbol	Parameter	Min	Typ	Max	Unit
Freq	Frequency range	2		22	GHz
Gain	Linear Gain		15		dB
NF	Noise Figure		3		dB
IRL	Input Return Loss		17		dB
ORL	Output Return Loss		17		dB
P <sub>1dB</sub>	Output power for 1dB Gain Compression		18		dBm
P <sub>sat</sub>	Saturated output power		20		dBm
OIP3	Output Third Order Intercept		30		dBm
Idq	Quiescent current on Vd		100		mA
Vd	Supply voltage on Vd	4.5	5	5.5	V
Id	Drain current @3dB gain compression		120		mA

The values are representative of typical “test fixture” measurements as defined on the drawing in paragraph “Evaluation test fixture”.

## Typical Bias Conditions

Tamb. = +25°C

Symbol	Pad N°	Parameter	Values	Unit
Vg1	6	Gate control1 for the amplifier	-0.4	V
Vg2	2	Gate control2 for the amplifier	1.7	V
Vd	3	Drain Voltage	5	V

The associated drain current with no RF input power is Idq = 100mA

This typical bias is recommended in order to get the best compromise between output power, linearity and Noise Figure performance vs. Temperature.

**Absolute Maximum Ratings** <sup>(1)</sup>T<sub>amb.</sub> = +25°C

Symbol	Parameter	Values	Unit
V <sub>d</sub>	Drain bias voltage	7V	V
I <sub>dq</sub>	Drain bias current	190	mA
V <sub>g1</sub>	Gate bias voltage V <sub>g1</sub>	-2 to 0	V
V <sub>g2</sub>	Gate bias voltage V <sub>g2</sub>	-2 to 2	V
P <sub>in</sub>	Maximum peak input power overdrive	15	dBm
T <sub>a</sub>	Operating temperature range (chip backside)	-40 to 85	°C
T <sub>stg</sub>	Storage temperature range	-55 to +150	°C

<sup>(1)</sup> Operation of this device above any one of these parameters may cause permanent damage: these maximum ratings parameters could not be cumulated.

These are stress ratings only, and functional operation of the device at these conditions is not implied.

Maximum Junction temperature = 115°C with T<sub>a</sub> = +85°C.

R<sub>th\_equivalent</sub> = 60°C/W → chip's equivalent thermal resistance from channel to die bottom with T<sub>a</sub> = +85°C and 5V & I<sub>dq</sub> = 100mA.

The R<sub>th\_equivalent</sub> is extrapolated, taking into account the full DC power and the channel temperature increase on the hottest transistor.

**Typical Jig Measurements**

Tamb. = +25°C, Vd = 5V, Vg1 set in order to get Idq = 100mA, Vg2 = 1.7V

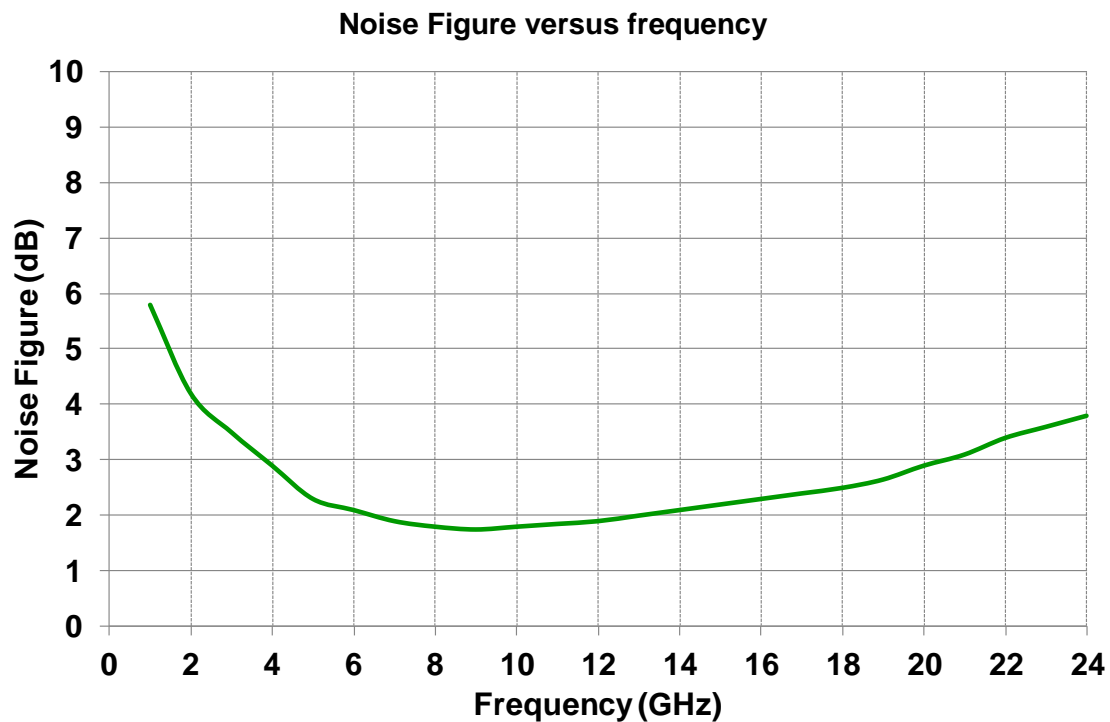
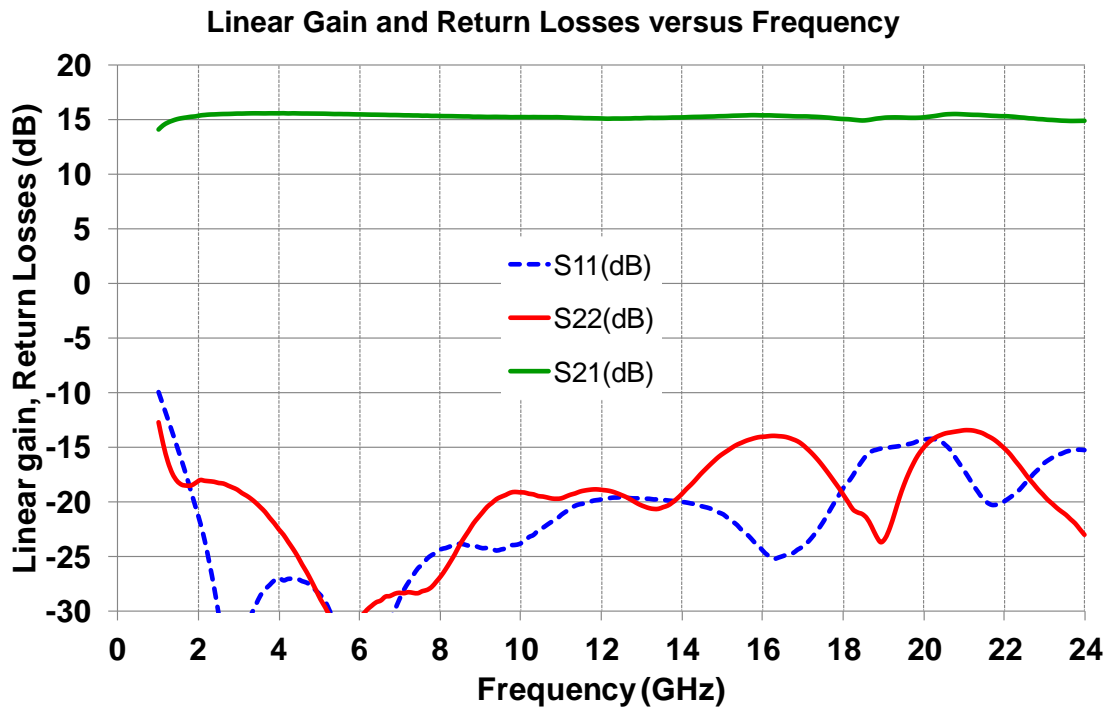

**Typical Jig Measurements**

Tamb. = +25°C, Vd = 5V, Vg1 set in order to get Idq = 100mA, Vg2 = 1.7V

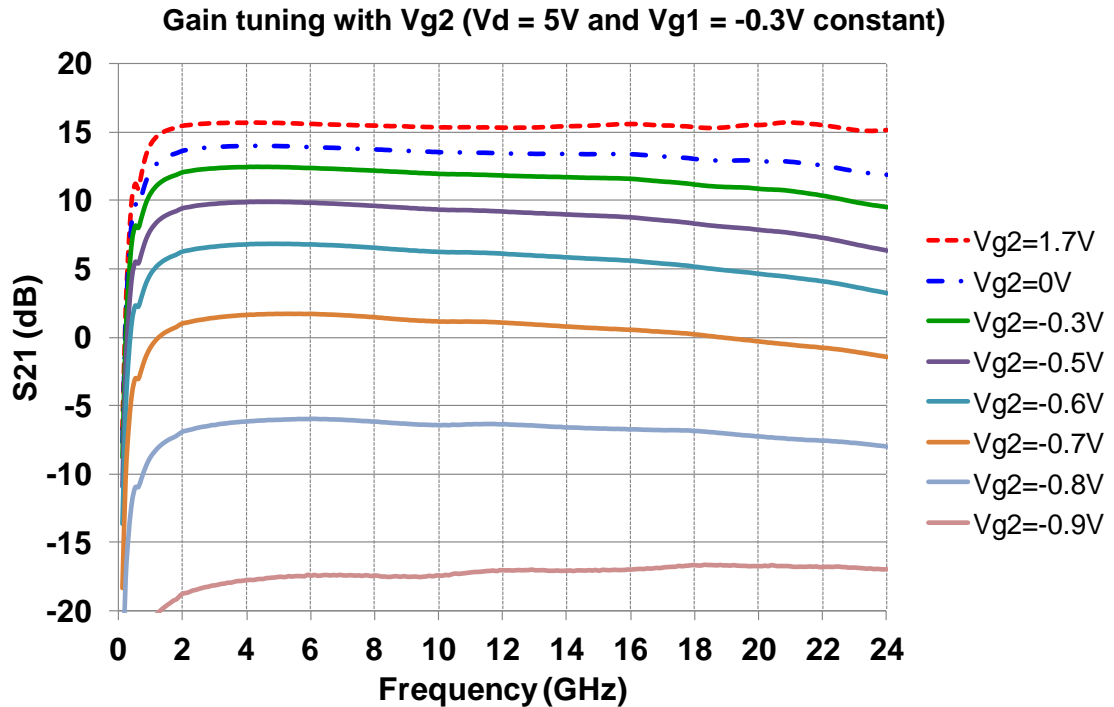
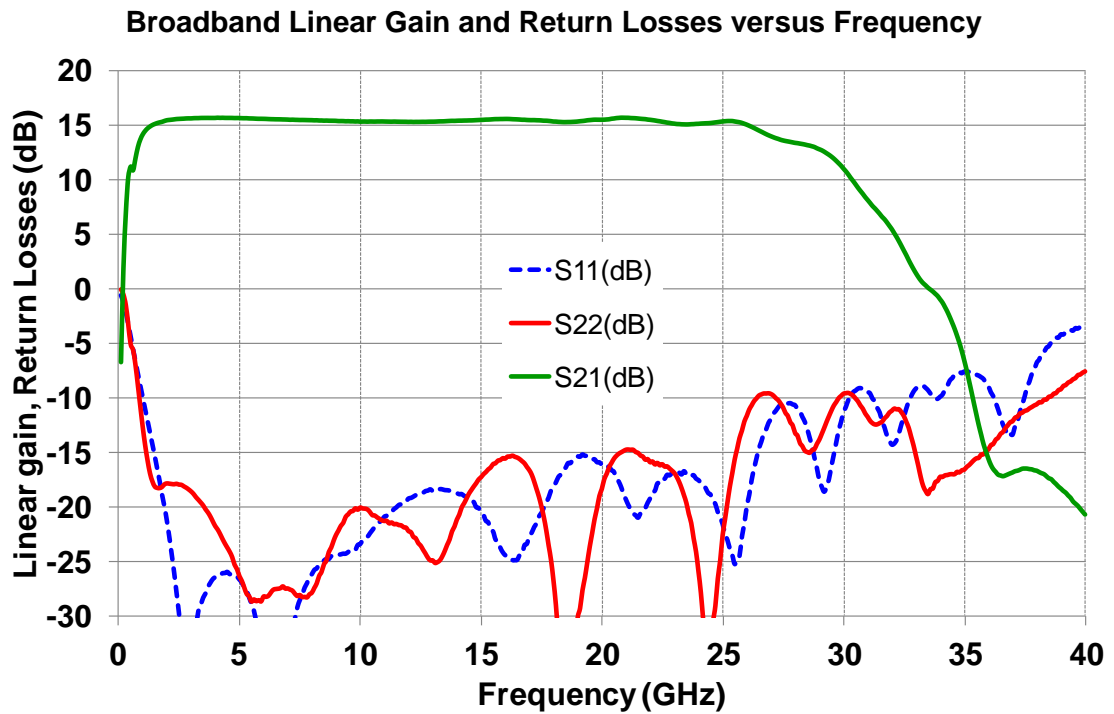

**Typical Jig Measurements**

Tamb. = +25°C, +85°C, -40°C, Vd = 5V, Vg1 set in order to get Idq = 100mA, Vg2 = 1.7V  
 Vg1 and Vg2 remain constant versus temperature.

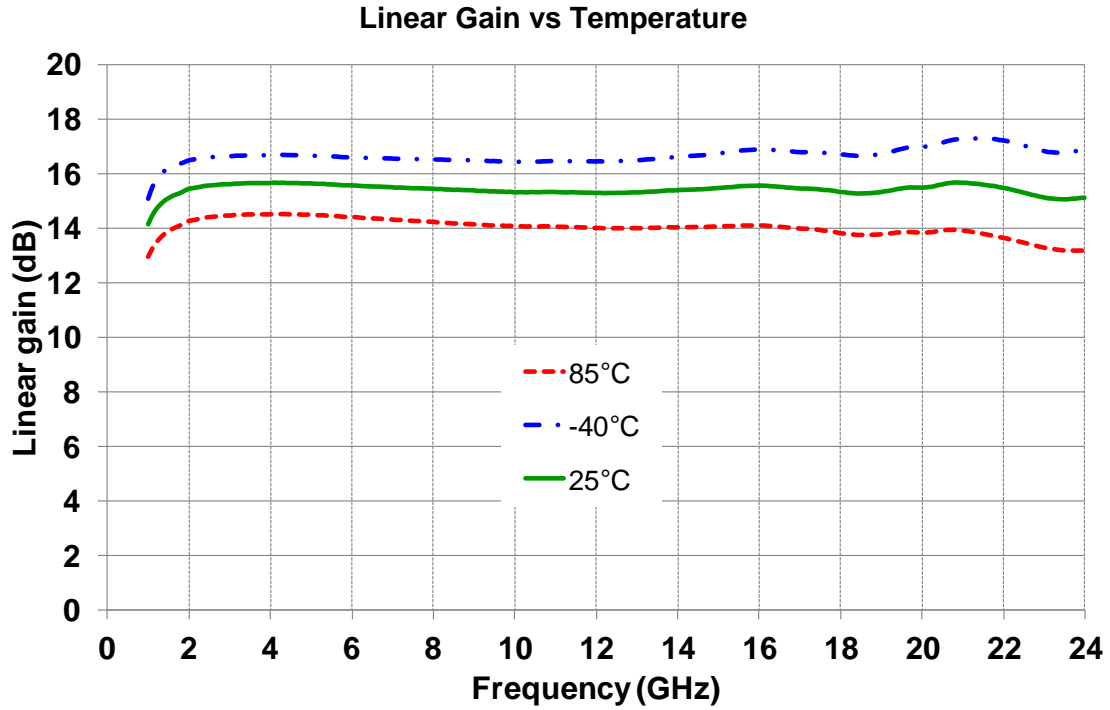

### Typical Jig Measurements

Temperature = +25°C, Vd = 5V, Vg1 set in order to get Idq = 100mA, Vg2 = 1.7V

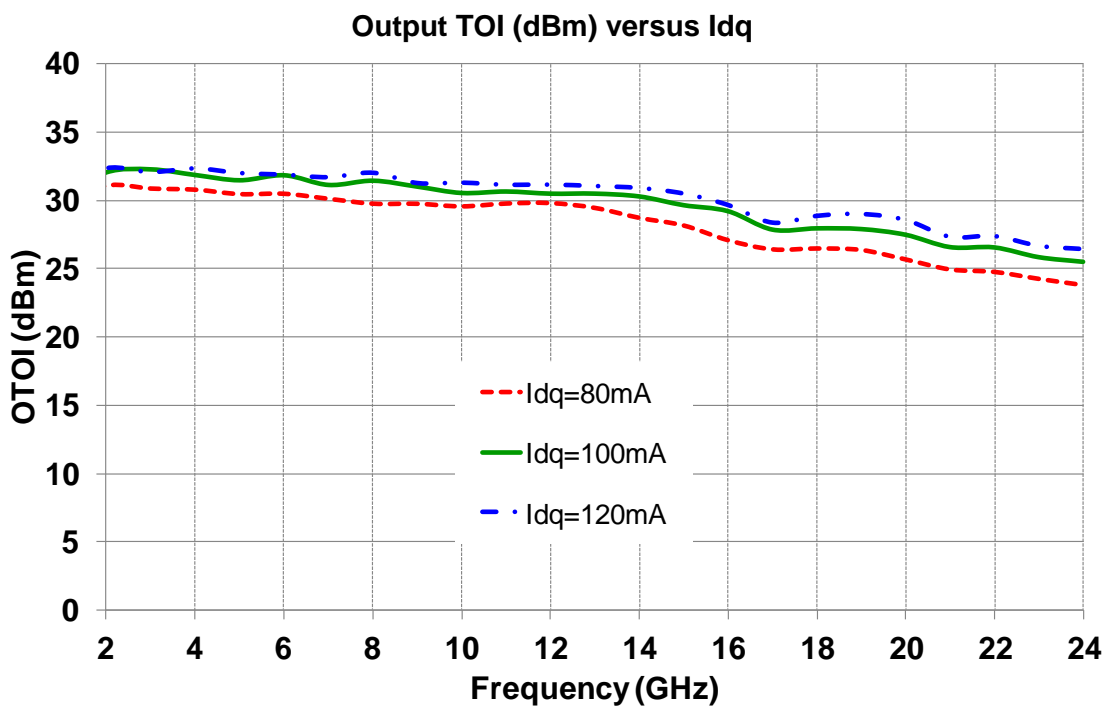
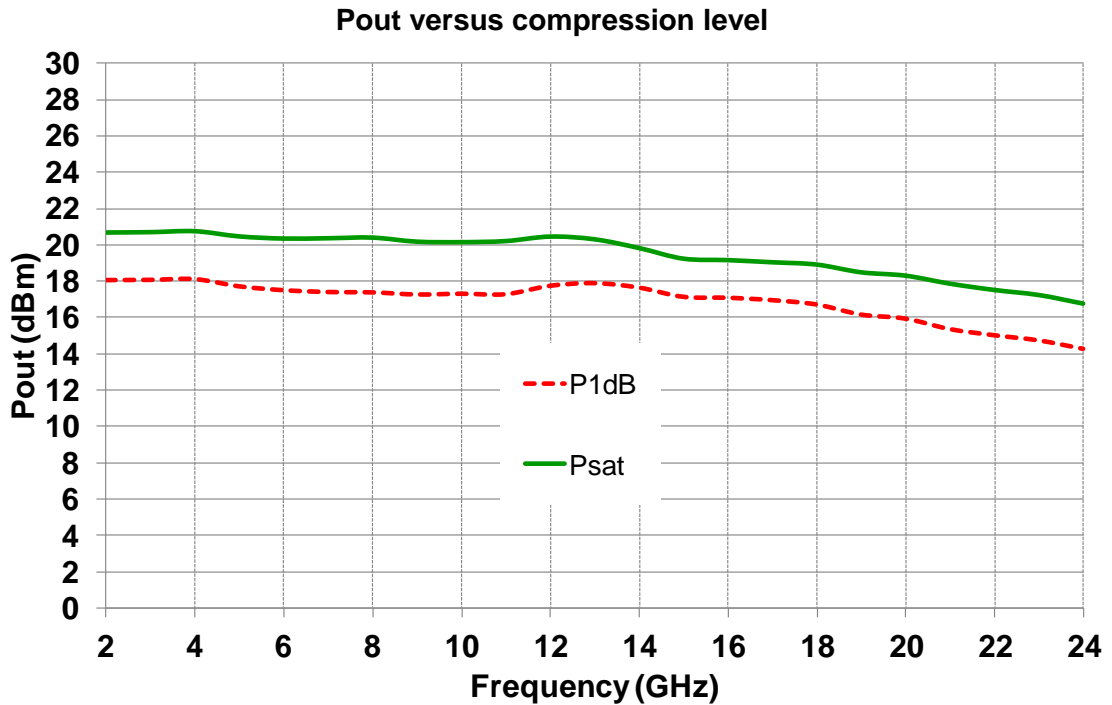

**Mechanical Data: outline drawing**

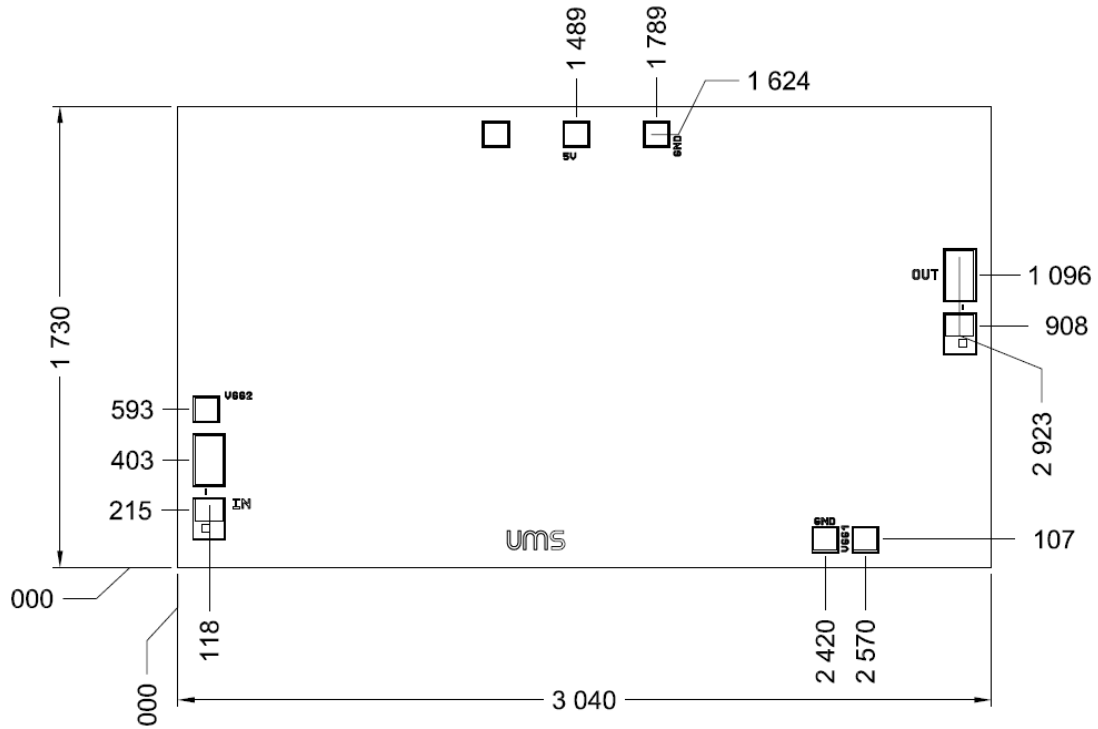

Chip size: 3040 μm x 1730 μm

Chip width and length are given with a tolerance of +/- 35μm.

Chip thickness is 100μm.

All pads are 100 μm x 100 μm, except IN and OUT pads that are 200 x 120 μm.



**PAD Reference**

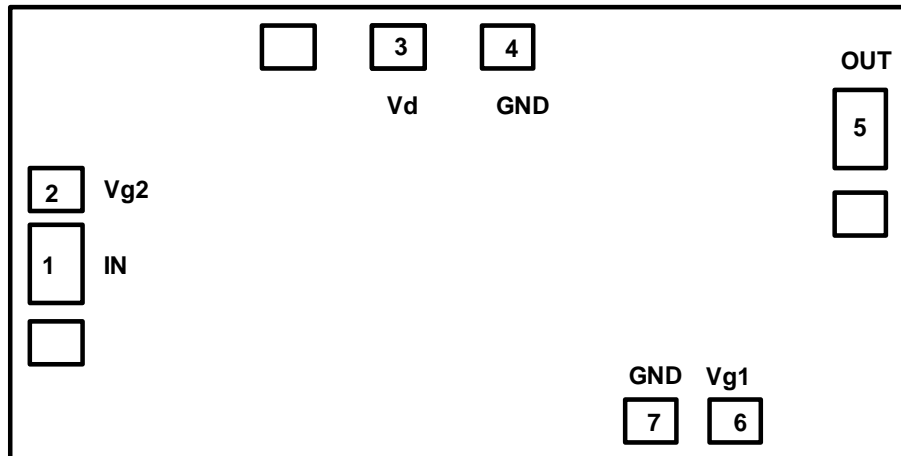

PAD Number	Name	Description
1	IN	RFIN is matched to 50 ohms
2	Vg2	Gate control 2 for amplifier: +1.7V should be applied for nominal operation.
3	Vd	Drain voltage of the part (5V)
4	GND	Not connected
5	OUT	RFOUT is matched to 50 ohms
6	Vg1	Gate control 1 for amplifier: about -0.3V for Idq=100mA
7	GND	Not connected
Die bottom	GND	Die bottom must be connected to RF/DC ground

**Assembly Recommendations**

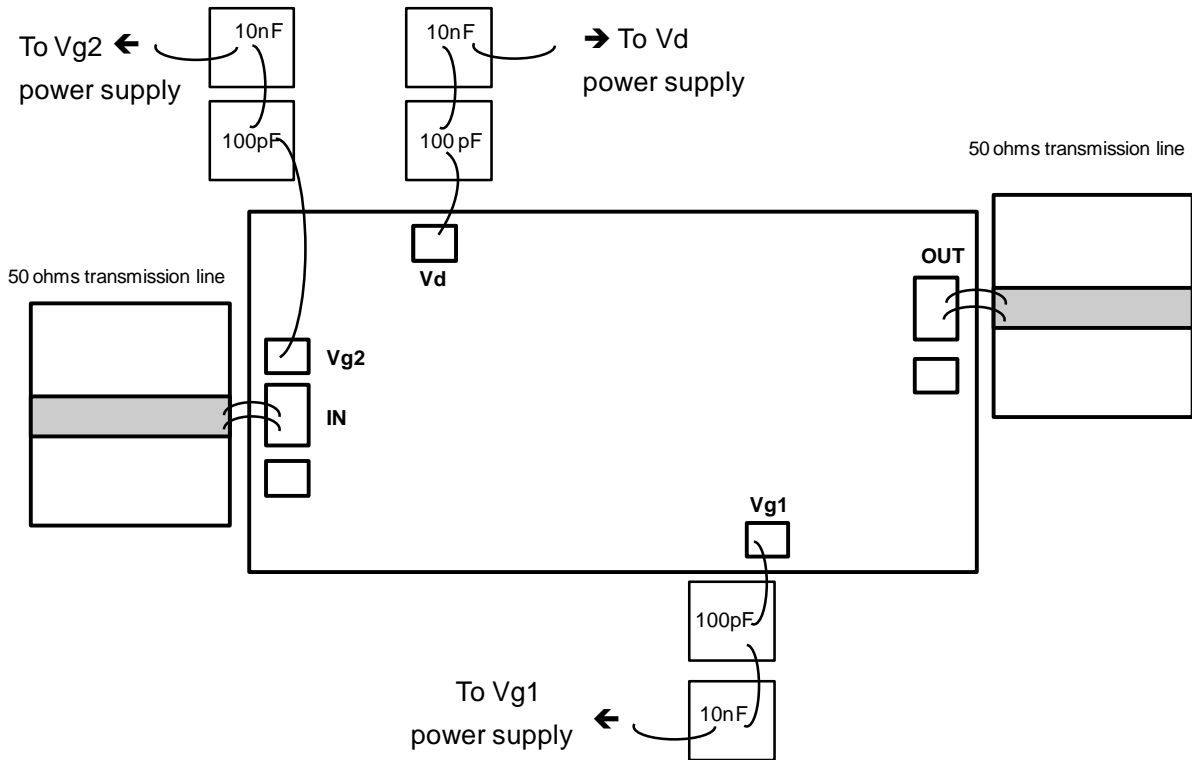

**Evaluation test fixture**

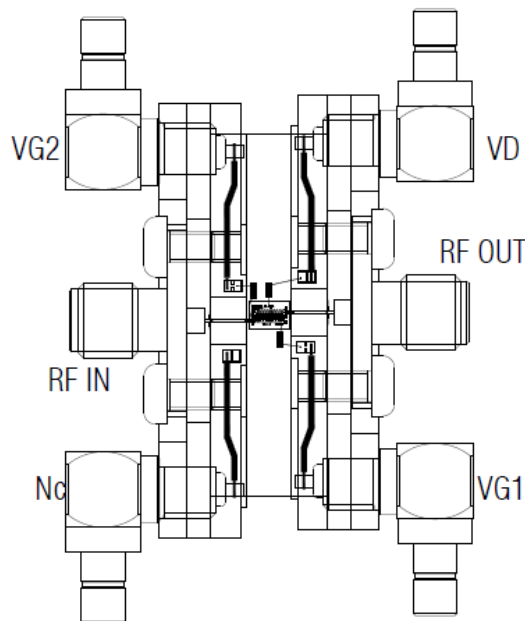

## Device Operation

### Device Power Up instructions:

- 1) Ground the device
- 2) Set  $V_{g1}$  to -2V
- 3) Set  $V_{g2}$  to 1.7V (nominal value for  $V_{g2}$ )
- 4) Set  $V_d$  to 5V (nominal value for  $V_d$ )
- 5) Set  $V_{g1}$  in the range of -0.3V for having  $I_{dq} = 100\text{mA}$
- 6) Apply RF input power

### Device Power Down instructions:

- 1) Remove RF input power
- 2) Remove  $V_d$
- 3) Remove  $V_{g2}$
- 4) Remove  $V_{g1}$

## DC Schematic

$V_d = 5\text{V}$ ,  $V_{g1} = -0.3\text{V}$ ,  $V_{g2} = 1.7\text{V}$ ,  $I_{dq} = 100\text{mA}$

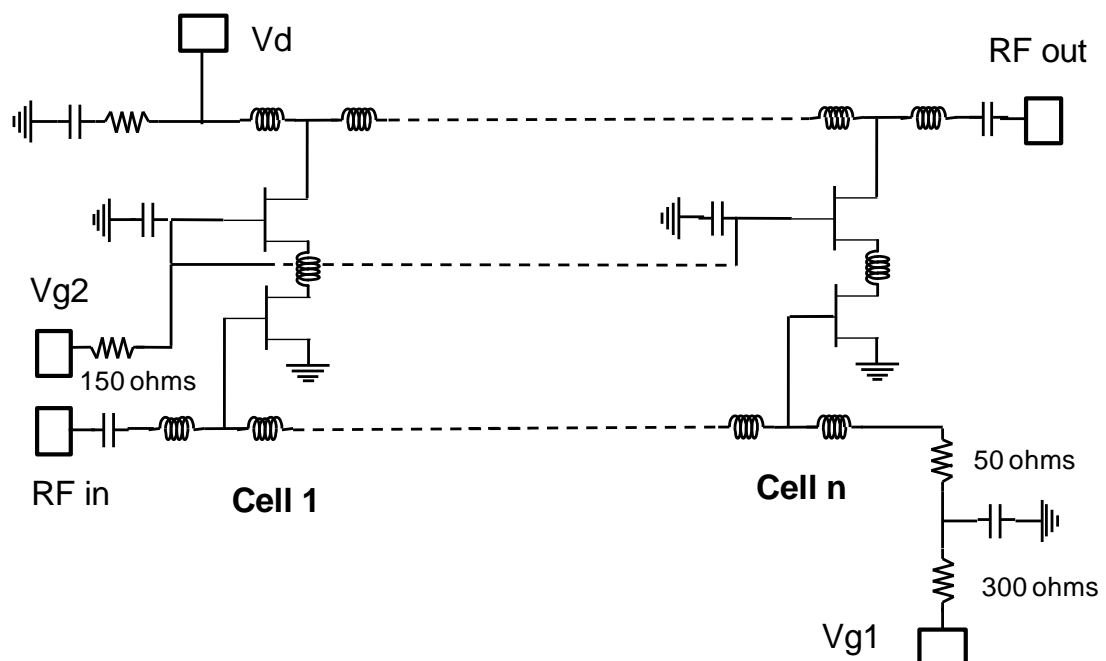

## Recommended environmental management

UMS products are compliant with the regulation in particular with the directives RoHS N°2011/65 and REACH N°1907/2006. More environmental data are available in the application note AN0019 also available at <http://www.ums-gaas.com>.

## Recommended ESD management

Refer to the application note AN0020 available at <http://www.ums-gaas.com> for ESD sensitivity and handling recommendations for the UMS package products.

## Ordering Information

Chip form:

CHA3024-99F/00

Information furnished is believed to be accurate and reliable. However **United Monolithic Semiconductors S.A.S.** assumes no responsibility for the consequences of use of such information nor for any infringement of patents or other rights of third parties which may result from its use. No license is granted by implication or otherwise under any patent or patent rights of **United Monolithic Semiconductors S.A.S.**. Specifications mentioned in this publication are subject to change without notice. This publication supersedes and replaces all information previously supplied. **United Monolithic Semiconductors S.A.S.** products are not authorised for use as critical components in life support devices or systems without express written approval from **United Monolithic Semiconductors S.A.S.**