

▪ **Outline Dimension Drawing**

Dimensions: mm[inch]

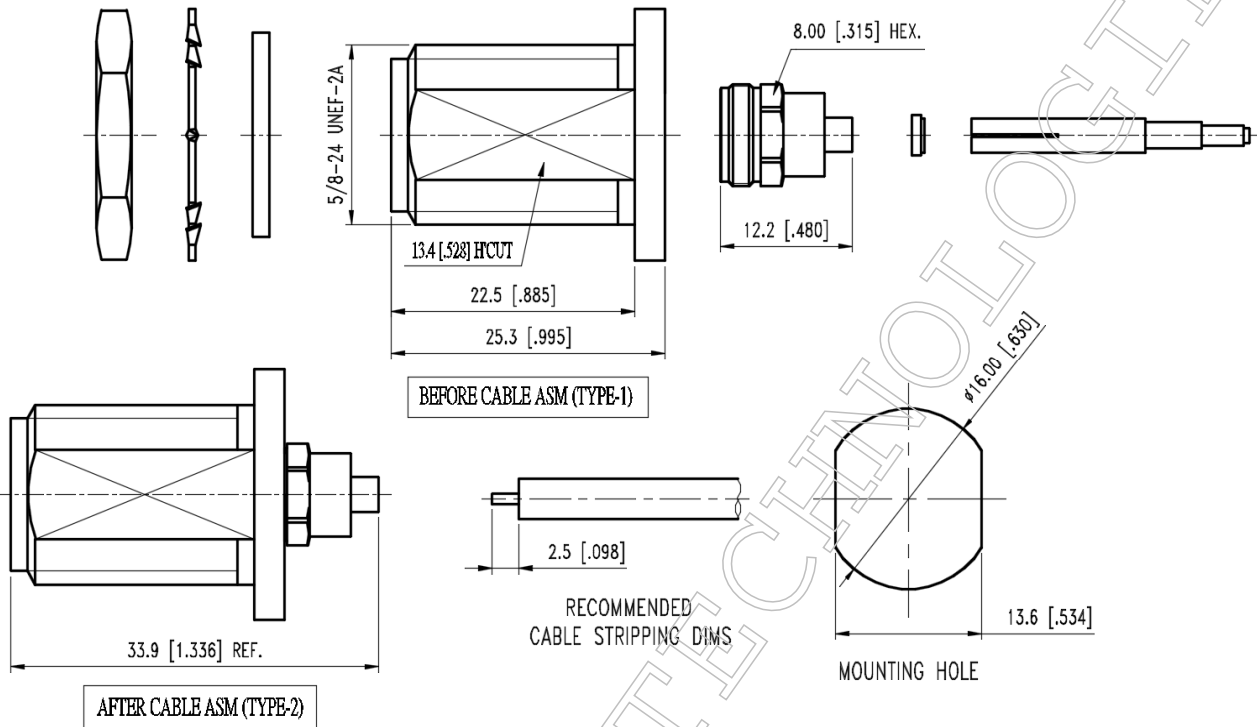

▪ **Material Specification**

Description	Material	Plating
Body*2	Brass	Silver
Contact	BeCu	Gold
Dielectric*2	PTFE	
Nut	Brass	Silver
G-ring	Brass	Silver
Gasket	S.I.R	Red
Washer	P.Bronze	Silver

In the effort to improve our products, we reserve the right to make changes judged to be necessary



▪ **Electrical Specification**

Description			Description		
Impedance	50	Ω	Insulation Resistance	5000	MΩ Min.
Frequency	11	GHz	Inner Contact Resistance	3	mΩ Max.
VSWR	1.3	Max.	Outer Contact Resistance	2	mΩ Max.
Insertion Loss	0.2	dB Max.			
Voltage Rating	335	Vrms Max.			
Dielectric Withstanding Voltage	750	Vrms Max.			

▪ **Mechanical Specification**

Description			Description		
Center Contact			Recommended Torque	12~15	in. lbs
Axial Force-Mating End	N/A	lbs.	Coupling Nut Retention	N/A	in. lbs
Axial Force-Opposite End	N/A	lbs.			
Connector Durability	500	cycles			
Weight	N/A	g			

▪ **Environmental Specification**

Description		
Temperature Min.	-55	°C
Temperature Max.	165	°C
Hermetic Seal	N/A	

In the effort to improve our products, we reserve the right to make changes judged to be necessary