

▪ **Outline Dimension Drawing**

Dimensions: mm[inch]

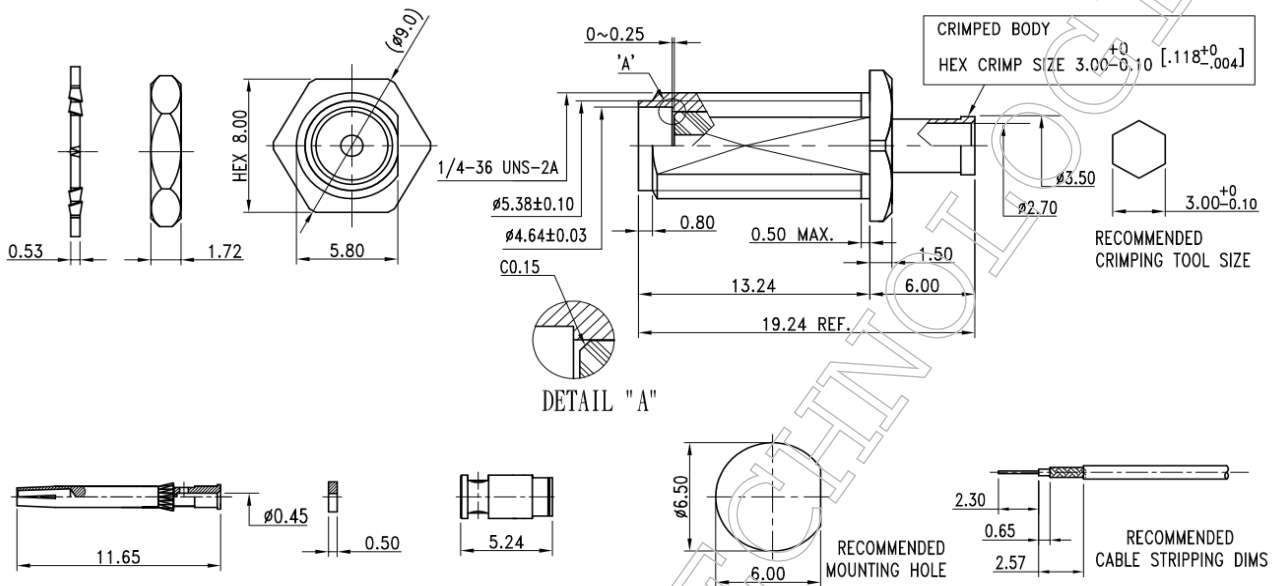

▪ **Material Specification**

Description	Material	Plating
Body	Brass	Gold
Contact	BeCu	Gold
Dielectric*2	PTFE	
Ring	Brass	Gold
Nut	Brass	Gold
Washer	Brass	Gold

In the effort to improve our products, we reserve the right to make changes judged to be necessary



▪ **Electrical Specification**

Description			Description		
Impedance	50	Ω	Insulation Resistance	5000	MΩ Min.
Frequency	6	GHz	Inner Contact Resistance	3	mΩ Max.
VSWR	1.3	Max.	Outer Contact Resistance	3	mΩ Max.
Insertion Loss	0.15	dB Max.			
Voltage Rating	250	Vrms Max.			
Dielectric Withstanding Voltage	500	Vrms Max.			

▪ **Mechanical Specification**

Description			Description		
Center Contact			Recommended Torque	7~9	in. lbs
Axial Force-Mating End	N/A	lbs.			
Axial Force-Opposite End	N/A	lbs.			
Connector Durability	500	cycles			
Weight	N/A	g			

▪ **Environmental Specification**

Description		
Temperature Min.	-65	°C
Temperature Max.	165	°C
Hermetic Seal	N/A	

In the effort to improve our products, we reserve the right to make changes judged to be necessary