

## FEATURES

- 22/26 dBm P1dB/PSAT
- E2-band coverage
- 31 dBm OIP3
- 20 dB gain

## TYPICAL APPLICATIONS

- Point-to-point communication
- Instrumentation
- Fiber over radio
- 77 GHz automotive radar

## DESCRIPTION

gAPZ0042 is a power amplifier in the 81-86 GHz frequency band suitable for E-band point-to-point communication and 77 GHz automotive radar. The PA's output stage has four parallel HEMTs to increase output power. The PA has high gain, high linearity, low input/output return loss and flat gain response.

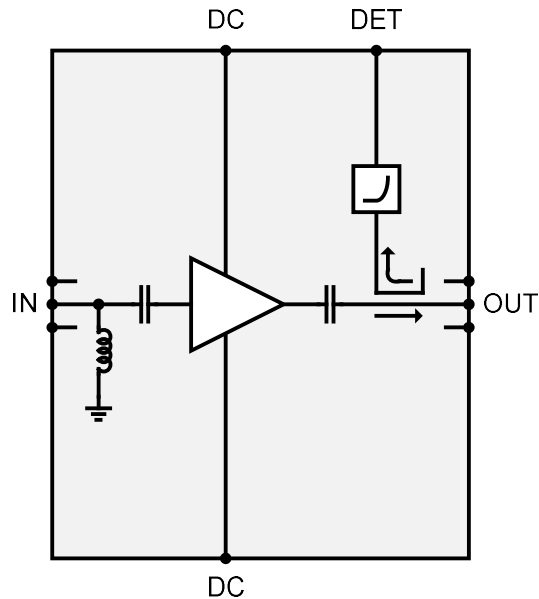

Figure 1. Block diagram of the PA.

## ELECTRICAL PERFORMANCE

Table 1. Electrical performance  $T_A=25^\circ\text{C}$

Parameter	Min	Typ	Max	Unit
Frequency	81 (75)		86 (90)	GHz
Gain	18	20	22	dB
P1dB	21	22	23	dBm
PSAT	25	26	27	dBm
OIP3	29	30	31	dBm
PAE			15	%
Input return loss	8			dB
Output return loss	20			dB
Power consumption		2145		mW

## MEASURED PERFORMANCE

The chip has been measured on-wafer using CW and 2-tone input test signals. The PA uses typical bias settings if not specified differently.

Table 2. Test conditions

Parameter	Setting
RF input power	-10 dBm/tone
RF input frequency	83.5 GHz
Frequency separation	10 MHz
Temperature	25°C

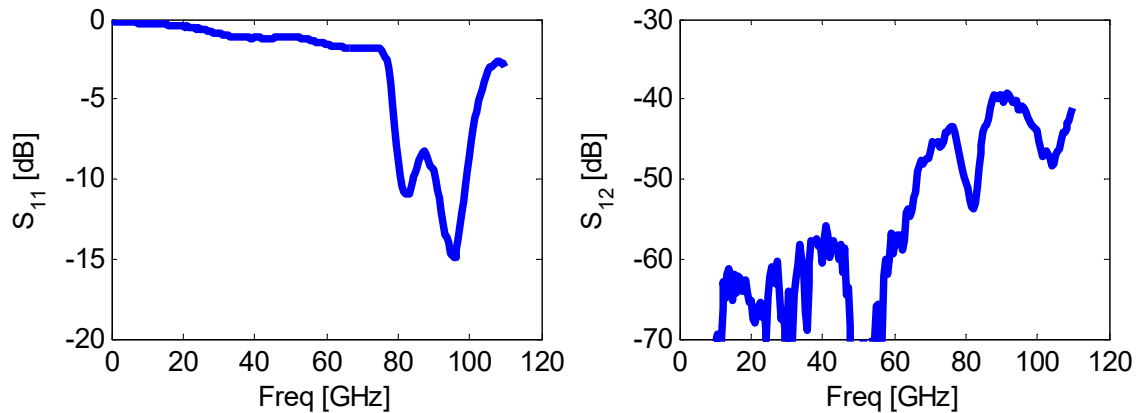

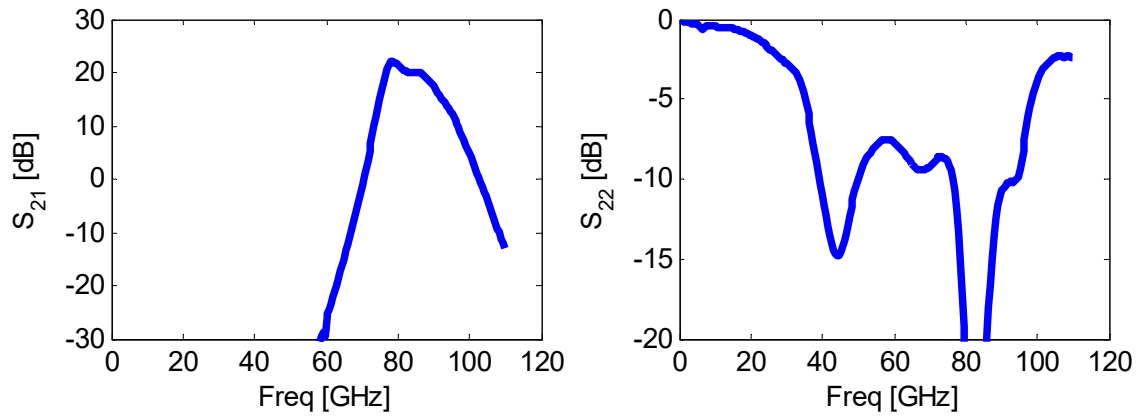

Figure 2. Small signal response from 0-120 GHz at nominal bias. (Upper left): Input return loss. (Upper right): Reverse isolation. (Lower left): Small-signal gain. (Lower right): Output return loss.

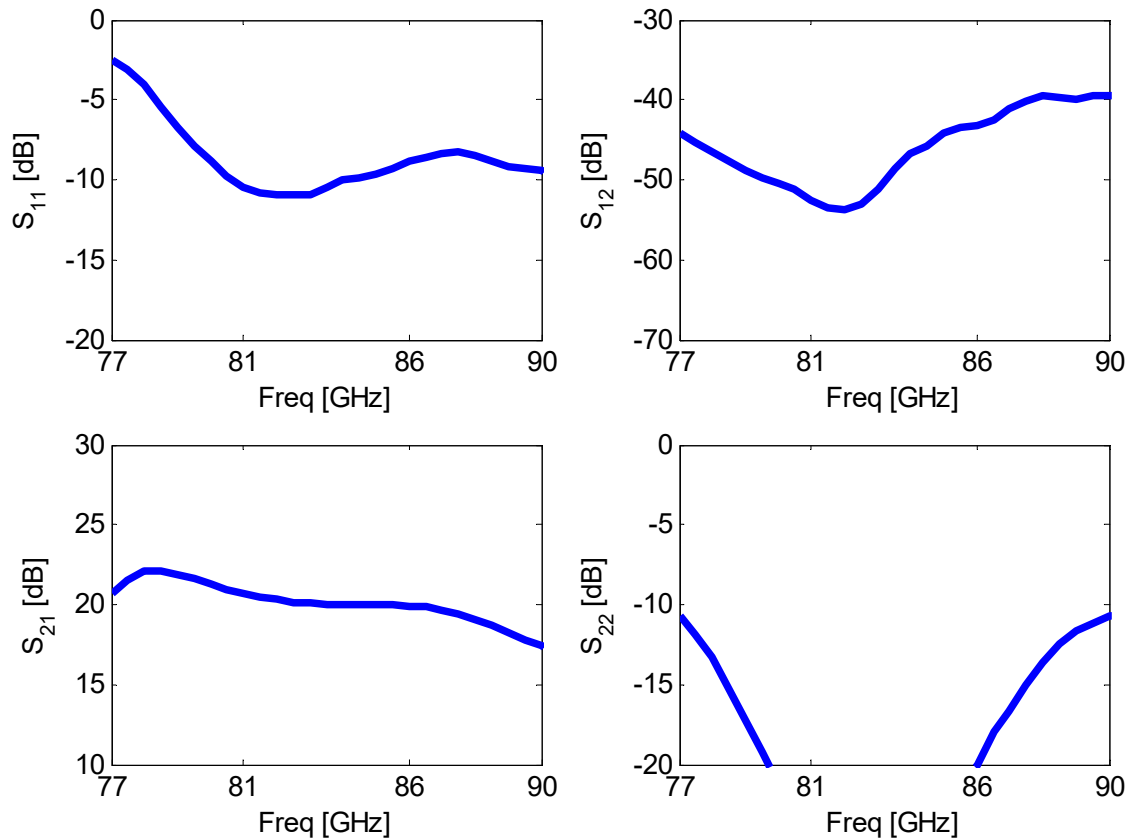

Figure 3. Small signal response within the E2-band at nominal bias. (Upper left): Input return loss. (Upper right): Reverse isolation. (Lower left): Small-signal gain. (Lower right): Output return loss.

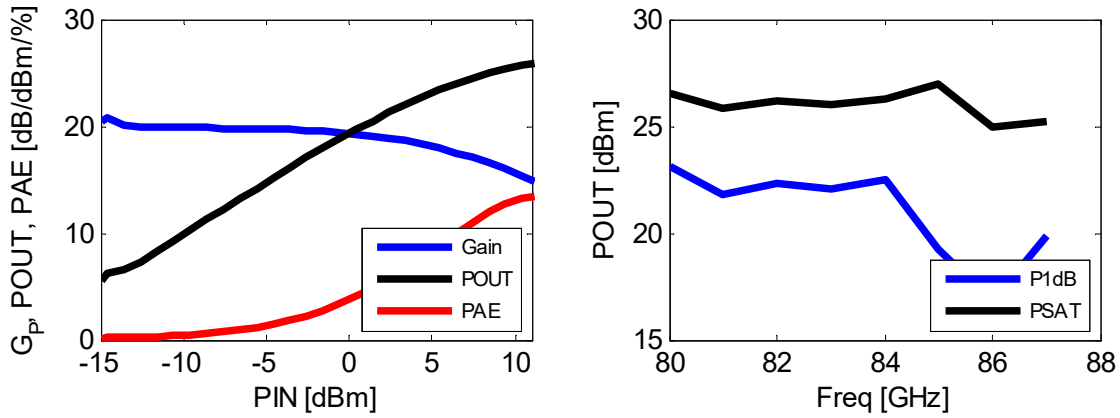

Figure 4. (Left): Output power, gain and PAE vs input power at 83.5 GHz. (Right): P1dB and PSAT vs freq.

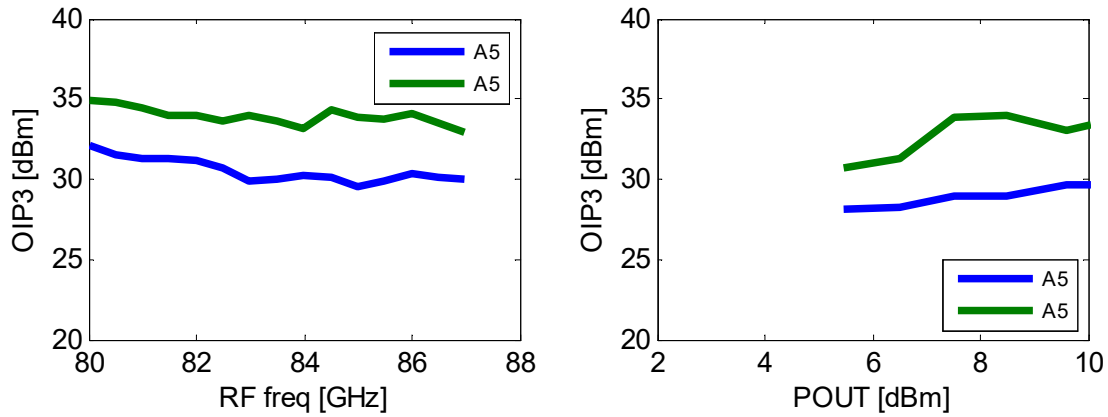

Figure 5. (Left): OIP3 vs frequency. (Right): OIP3 vs output power at 83.5 GHz.

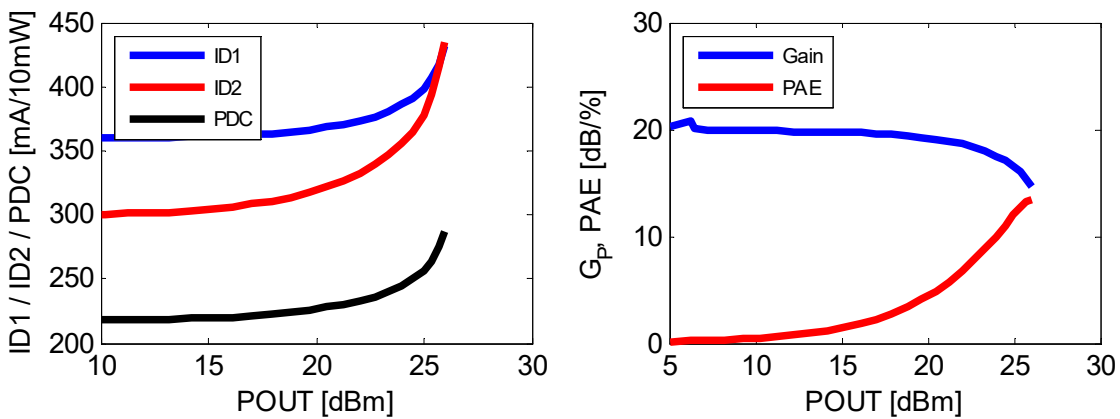

Figure 6. (Left): Power dissipation and drain currents ID1 and ID2 vs output power at 83.5 GHz. (Right): Efficiency and gain vs output power at 83.5 GHz.

## RECOMMENDED OPERATING CONDITIONS

Bias should first be applied to the gates (VG...) followed by the drains (VD...). The gate voltages must be adjusted within the min/max range indicated in Table 3-5 to obtain the specified drain currents. The drain currents are stated with no input signal.

Table 3. Electrical settings on connector P1

Connector P1	Pad No.	Bias settings (V/mA)			I/O
		Min	Typ	Max	
VOUT_DET	1	0		3.3	Output
VREF_DET	2	0	0.2		Output
VG_DET <sup>[1]</sup>	3	-1.0	-0.8	-0.6	Input
VD_DET	4	3.2	3.3 / 0	3.4	Input
VD2 <sup>[2]</sup>	5	3.2	3.3 / 300 <sup>[3]</sup>	3.4	Input
GND	6				Ground
VD2 <sup>[2,3]</sup>	7	3.2	3.3 / 300	3.4	Input
VG2 <sup>[2,3]</sup>	8	-0.7	-0.5	-0.3	Input
VG1 <sup>[2,3]</sup>	9	-0.7	-0.5	-0.3	Input
VD1 <sup>[2,3]</sup>	10	3.2	3.3 / 350	3.4	Input

Table 4. Electrical settings on connector P2

Connector P2	Pad No.	Interface	I/O
GND	1		Ground
RF_OUT	2	Z <sub>0</sub> = 50 Ohm, AC coupled	Output
GND	3		Ground

<sup>[1]</sup> Maximum sensitivity is achieved at threshold voltage. Lower VG\_DET until the current reaches 0 mA on VD\_DET.

<sup>[2]</sup> VG1, VG2, VD1 and VD2 are physically connected across the chip via P1 and P3. Both connectors must be biased for maximum performance.

<sup>[3]</sup> Total current for connectors P1 and P3.

Table 5. Electrical settings on connector P3

Connector P3	Pad No.	Bias settings (V/mA)			I/O
		Min	Typ	Max	
VD1 <sup>[2,3]</sup>	1	3.2	3.3 / 350	3.4	Input
VG1 <sup>[2,3]</sup>	2	-0.7	-0.5	-0.2	Input
VG2 <sup>[2,3]</sup>	3	-0.7	-0.5	-0.2	Input
VD2 <sup>[2,3]</sup>	4	3.2	3.3 / 300	3.4	Input
GND	5				Ground
VD2 <sup>[2,3]</sup>	6	3.2	3.3 / 300	3.4	Input
NC	7				NC
NC	8				NC
NC	9				NC

Table 6. Electrical settings on connector P4

Connector P4	Pad No.	Interface	Function
GND	1		Ground
RF_IN	2	Z <sub>0</sub> = 50 Ohm, AC coupled	Input
GND	3		Ground

## ABSOLUTE MAXIMUM RATINGS

Table 7. Absolute maximum ratings

Gate-source voltage	-2 to +0.7 V
Drain-source voltage	4.5 V
Gate-drain breakdown voltage	8 V
ID1, ID2	720 mA
RF input power	+15 dBm
Operating temperature	-40 to + 85°C
Storage temperature	-65 to +150°C

## OUTLINE DRAWING

Mechanical drawing with pad locations is also available in dxf-file format on the web. The substrate thickness is 50  $\mu\text{m}$  (GaAs).

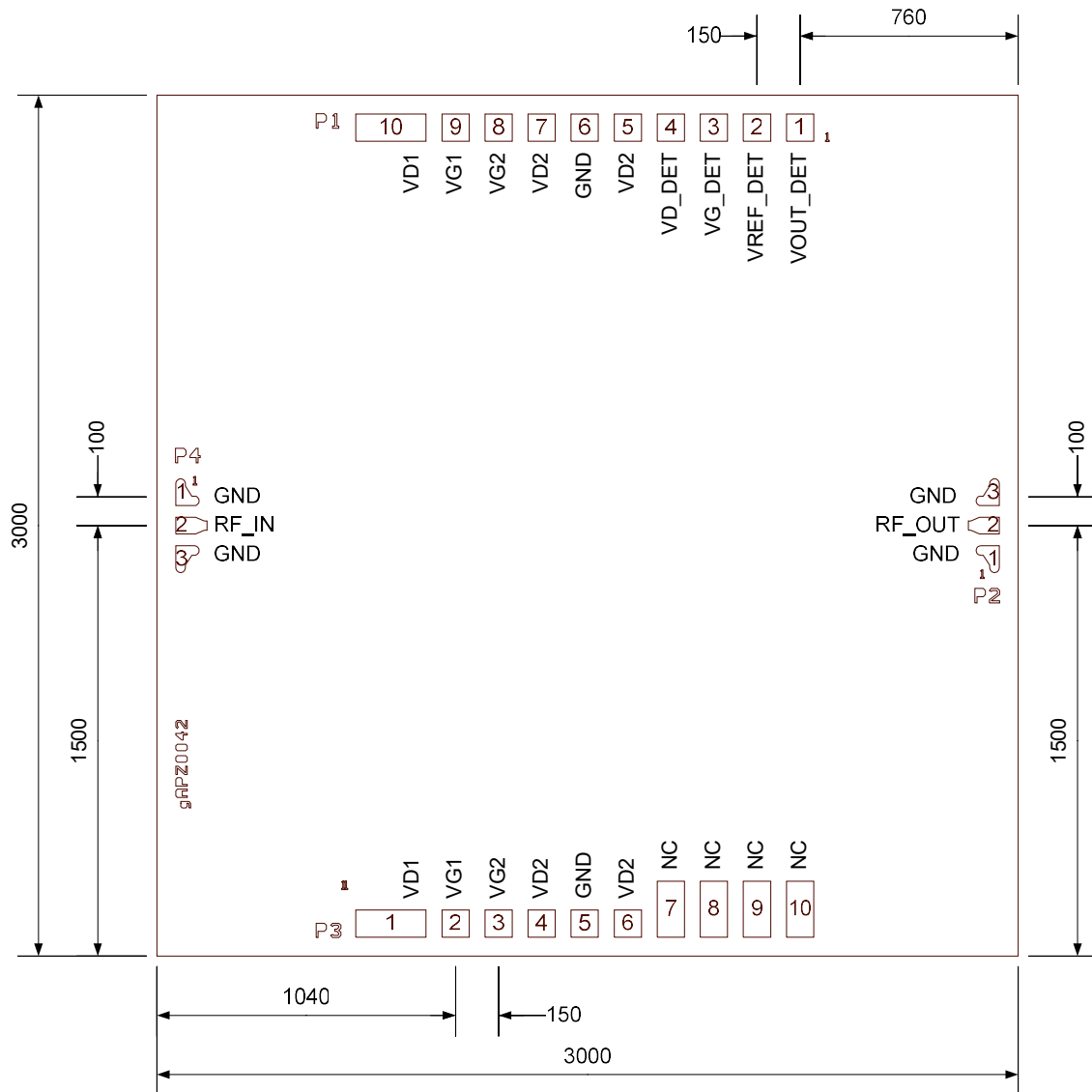

Figure 7. Outline drawing of the MMIC. Dimensions are in  $\mu\text{m}$ .